

Field-Portable Ultrasonic Transit-Time Liquid Flow Meter

FEATURES

- One meter for a wide range of pipe sizes from 2 to 236 inches (50.8 to 6000 mm)
- Fully field-portable, lightweight, and totally self-contained flow measurement package with 11.1 VDC rechargeable lithium-ion battery (continuous operation for up to 10 hours)
- Clamp-on sensors require no pipe cutting or process interruption, no plant shutdown, and are a hygienic measurement leading to lower installation and labor costs
- Two 12-inch magnetic transducer racks for easy attachment to magnetic pipes with flexibility to be moved to smaller pipes without tools
- Accuracy +/- 0.5% of reading from 0.03 to 40 ft/s (0.01 to 12 m/s)
- Repeatability +/- 0.1% of full scale
- Wide operating temperature range -40°F to 176°F (-40°C to 80°C)
- Encapsulated transducers; IP 68 with 16 ft (5m) standard cable
- NEMA 13 (IP 54) transmitter with 3.5-inch backlit color screen (320 x 240) with new flow graph display
- 24 tactile keys with 12 dual-function and 7 quick setup keys
- Analog out 4 to 20 mA (max 750 Ω)
- 2 GB SD memory card for high-capacity data logging. 48 hour total time.



www.sierrainstruments.com



INNOVASONIC 210



DESCRIPTION

Sierra's portable Innovasonic® 210 ultrasonic clamp-on liquid flow meter enables the user to do flow measurement checks at many points in a flow process without the need for a permanent installation.

Battery powered, lightweight, and rugged, the 210 is a totally self-contained flow measurement package. 210 comes standard with a sturdy and convenient pelican carrying case, transducers installed into compact, easy to set up mounting racks (magnetic & cable mount), coupling compound and a start-up CD. Get high accuracy measurements in five minutes or less. This universal transit-time meter features a dual-function pushbutton interface, ergonomic handheld design and a beautiful backlit color digital display that significantly simplifies setup and data collection.

The 210 is ideal for precisely measuring a wide range of liquid flows. Its high-powered ultrasonic pulse with improved digital signal processing requires just one set of transducers for a wide range of pipe sizes and materials including metal, plastic and concrete. While principally designed for clean liquids, the 210 operates effectively with the minimal quantity of air bubbles or suspended solids found in most industrial applications.

The 210 provides a powerful and extremely user-friendly programming menu that includes instantaneous flow rate, positive total, negative total, net total, velocity, date & time, and daily flow results. Its 2 GB SD memory card promises high-capacity data logging and a rechargeable lithium-ion battery supports continuous operation up to 10 hours.

PERFORMANCE SPECIFICATIONS

Accuracy

+/- 0.5% of reading from 0.03 to 40 ft/s (0.01 to 12 m/s)

Repeatability

+/- 0.1% of full scale

Pipe Size

2 to 236 inches (50.8 to 6000 mm)

OPERATING SPECIFICATIONS

Flow Range

0.03 to 40 ft/s (0.01 to 12 m/s)

Temperature

Ambient: 14°F to 122°F (-10°C to 50°C)
 Operating: -40°F to 176°F (-40°C to 80°C)

Power Supply

11.1 VDC rechargeable lithium-ion battery (continuous operation of up to 10 hours)

Output

Analog: 4 to 20 mA current loop (max load 750 Ω)

Keypad

24 tactile keys with 12 dual-function and 7 quick setup keys

Display

3.5 inch backlit color LCD display (320 x 240)

Humidity

Up to 99% RH (non-condensing)

Data Logging

2 GB SD memory card for high-capacity data logging
 1 minute to 48 hour collection time

PHYSICAL SPECIFICATIONS

Transmitter

NEMA 13 (IP 54)

Transducer

Encapsulated design IP 68
 Standard cable length: 16 ft (5 m)
 Maximum cable length: 100 ft (30 m)

Electronics Dimensions

Transmitter: H = 7.8 inches (19.5 cm) W = 5.3 inches (13.5 cm) D = 1.4 inches (3.5 cm)
 Transducer: H = 11.75 inches (29.85 cm) W = 1.5 inches (3.81 cm) D = 1.5 inches (3.81 cm)

Weight

Transmitter: 1.4 lbs (.6 kg)
 Transducer: 1 lbs (.4 kg)

OPTIMAL INSTALLATION LOCATION

Transducer Installation Examples

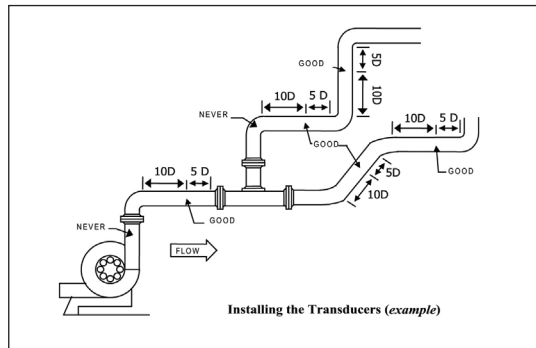

TRANSDUCER SPACING REQUIREMENTS

Z Method Transducer Spacing

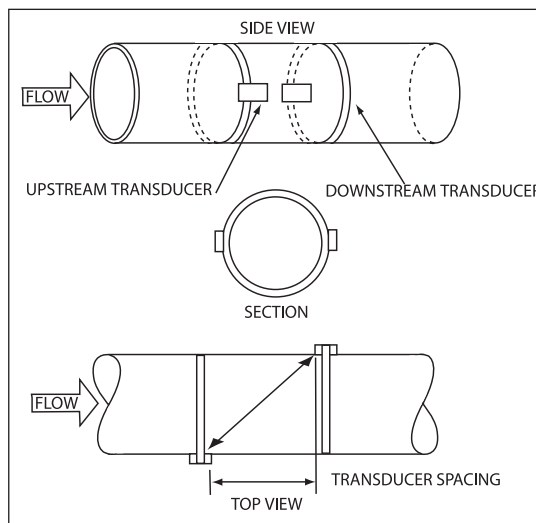

V Method Transducer Spacing

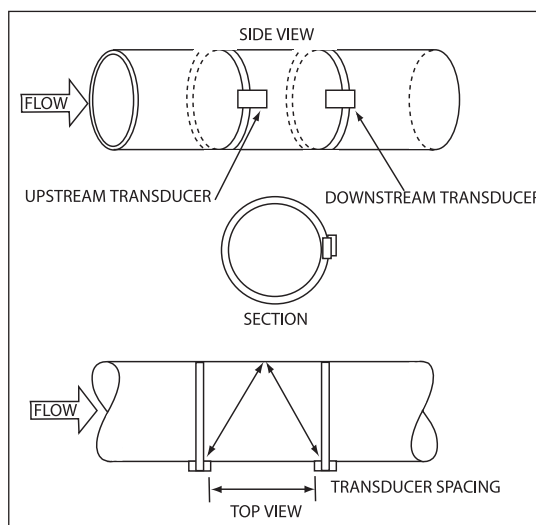



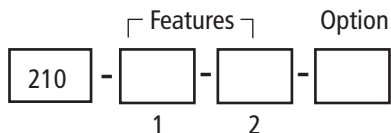

Instructions: To order the 210, please fill in each number block by selecting the codes from the corresponding features below and following pages.

Parent Number	
210	InnovaSonic® Portable Ultrasonic Transit-Time Liquid Flow Meter
Feature 1: Interface	
1	Push-button data entry with 24 tactile keys; 12 dual function and 7 quick setup keys; comes with display
Feature 2: Transducer and Cable Length	
16	Clamp-on portable transducers with two magnetic mounting racks. Operating temperature -40°F to 176°F (-40°C to 80°C), 16 ft. (5m) standard cable length. Longer lead time for longer cable lengths.
Option: NIST Traceable Certificate	
NIST	5-point calibration certification traceable to NIST. Add two weeks to standard delivery.

Flexibility And Options.

Learn About Our New Rental Program.

How To Apply For Rental

- Visit <http://sierrainstruments.com/rental>
- Email Rental@SierraInstruments.com



In Stock Products. Ship In Three Days.*

<https://sierrainstruments.com/shop/210>



*Disclaimer: Dependent on availability of stock.