



CalTrak<sup>®</sup> 300

# CalTrak<sup>®</sup> 300 Primary Standard Gas Volume Flow Calibrator

*Hygiene & Health Applications*

## Instruction Manual

Models: 300-L, 300-M, and 300-H



Part Number: IM-CalTrak-300 Rev. V2 4/15



**SIERRA<sup>®</sup>**

EXPERIENCE OUR PASSION FOR FLOW!

## **GLOBAL SUPPORT LOCATIONS: WE ARE HERE TO HELP!**

### **CORPORATE HEADQUARTERS**

5 Harris Court, Building L Monterey, CA 93940  
Phone (831) 373-0200 (800) 866-0200 Fax (831) 373-4402  
[www.sierrainstruments.com](http://www.sierrainstruments.com)

### **EUROPE HEADQUARTERS**

Bijlmansweid 2 1934RE Egmond aan den Hoef  
The Netherlands  
Phone +31 72 5071400 Fax +31 72 5071401

### **ASIA HEADQUARTERS**

Second Floor Building 5, Senpu Industrial Park  
25 Hangdu Road Hangtoun Town  
Pu Dong New District, Shanghai, P.R. China  
Postal Code 201316  
Phone: + 8621 5879 8521 Fax: +8621 5879 8586

### **© COPYRIGHT SIERRA INSTRUMENTS 2014**

No part of this publication may be copied or distributed, transmitted, transcribed, stored in a retrieval system, or translated into any human or computer language, in any form or by any means, electronic, mechanical, manual, or otherwise, or disclosed to third parties without the express written permission of Sierra Instruments. The information contained in this manual is subject to change without notice.

### **TRADEMARKS**

CalTrak™, CalTrak®, CalSoft™, and SmartTrak® are trademarks of Sierra Instruments, Inc. Other product and company names listed in this manual are trademarks or trade names of their respective manufacturers.

# Warnings and Cautions

## Note and Safety Information

We use caution and warning statements throughout this book to draw your attention to important information.



### Warning!

This statement appears with information that is important to protect people and equipment from damage. Pay very close attention to all warnings that apply to your application.



### Caution!

This statement appears with information that is important for protecting your equipment and performance. Read and follow all cautions that apply to your application.



**Warning!** Agency approval for hazardous location installations varies between flow meter models. Consult the flow meter nameplate for specific flow meter approvals before any hazardous location installation.

**Warning!** All wiring procedures must be performed with the power off.

**Warning!** To avoid potential electric shock, follow National Electric Code safety practices or your local code when wiring this unit to a power source and to peripheral devices. Failure to do so could result in injury or death. All AC power connections must be in accordance with published CE directives.

**Warning!** Do not power the flow meter with the sensor remote (if applicable) wires disconnected. This could cause over-heating of the sensors and/or damage to the electronics.

**Warning!** Before attempting any flow meter repair, verify that the line is de-pressurized.

**Warning!** Always remove main power before disassembling any part of the mass flow meter/controller.



**Caution!** Before making adjustments to the device, verify the flow meter/controller is not actively monitoring or reporting to any master control system. Adjustments to the electronics will cause direct changes to flow control settings.

**Caution!** When using toxic or corrosive gases, purge the line with inert gas for a minimum of four hours at full gas flow before installing the meter.

**Caution!** The AC wire insulation temperature rating must meet or exceed 80°C (176°F).

**Caution!** Printed circuit boards are sensitive to electrostatic discharge. To avoid damaging the board, follow these precautions to minimize the risk of damage:

- before handling the assembly, discharge your body by touching a grounded, metal object
- handle all cards by their edges unless otherwise required
- when possible, use grounded electrostatic discharge wrist straps when handling sensitive components

## ***Receipt of System Components***

When receiving a Sierra mass flow meter, carefully check the outside packing carton for damage incurred in shipment. If the carton is damaged, notify the local carrier and submit a report to the factory or distributor. Remove the packing slip and check that all ordered components are present. Make sure any spare parts or accessories are not discarded with the packing material. Do not return any equipment to the factory without first contacting Sierra Customer Service.

## ***Technical Assistance***

If you encounter a problem with your flow meter, review the configuration information for each step of the installation, operation, and setup procedures. Verify that your settings and adjustments are consistent with factory recommendations. Installation information can be found in Chapter 2 of this manual, and troubleshooting information can be found in Chapter 10.

If the problem persists after following the troubleshooting procedures outlined in this manual, contact Sierra Instruments by fax or by E-mail (see inside front cover). For urgent phone support you may call (800) 866-0200 or (831) 373-0200 between 8:00 a.m. and 5:00 p.m. PST. In Europe, contact Sierra Instruments Europe at +31 (0)72-5071400. In the Asia-Pacific region, contact Sierra Instruments Asia at +86-21-58798521. When contacting Technical Support, make sure to include this information:

- The flow range, serial number, and Sierra order number (all marked on the meter nameplate)
- The software version (visible at start up)
- The problem you are encountering and any corrective action taken
- Application information (gas, pressure, temperature and piping configuration)

# Table of Contents

- Chapter 1: Introduction ..... 6**
- Chapter 2: Operation ..... 8**
- Chapter 3: Configuration ..... 16**
- Chapter 4: Annual Maintenance and Calibration ..... 17**
  - Assuring Top Performance and Accuracy ..... 17
- Chapter 5: Shipping ..... 18**
  - Returning Equipment to Factory ..... 18
- Chapter 6: Storage ..... 19**
  - Protecting Your CalTrak When Not In Use ..... 19
- Chapter 7: Product Specifications ..... 20**
  - Technical data about your CalTrak ..... 20
- Chapter 8: Default Settings..... 23**
- Chapter 9: Warranty Policy..... 24**
- Chapter 10: Troubleshooting..... 25**

# Chapter 1: Introduction

The CalTrak 300 is a portable primary standard gas volume flow calibrator for fast +/-1.0% of reading calibrations, delivering the accuracy, reliability and value needed to meet the demands of industrial hygiene and occupational health professionals. The 300 has a wide variety of uses, including quality control in the manufacturing of respirator equipment, personal sampling pumps and other hygiene equipment. CalTrak 300 is used by Occupational Safety and Health Administration (OSHA), Mine Safety Appliances (MSA), Military and many large hospital supply companies.

The 300 is very easy to use. Simply turn the CalTrak 300 on, connect it to the device under test (DUT), and start taking measurements. Instantly calibrate your gas flow using simple keypad commands. The 300's many user-selectable options make customizing your calibrations easy, giving you exactly what you need in the format you prefer, over a wide range of flow rates, temperature, humidity and other relevant factors.

This manual will provide the information needed to operate your CalTrak 300. If at any time you have questions regarding its operation, please contact Sierra through our web site ([www.sierrainstruments.com](http://www.sierrainstruments.com)) or call us at 800.866.0200 to speak with a member of our professional customer service staff.

## ***In Your CalTrak 300 Shipment***

Your CalTrak comes with the following:

- AC Power Adapter/Charger
- PC Serial Cable (RS-232)
- CalSoft Software
- Leak Test Caps (2); Save for use during the Leak Test
- Calibration Certificate
- Manual

Carrying cases and accessories are available for purchase from Sierra or your local Sierra Partner.

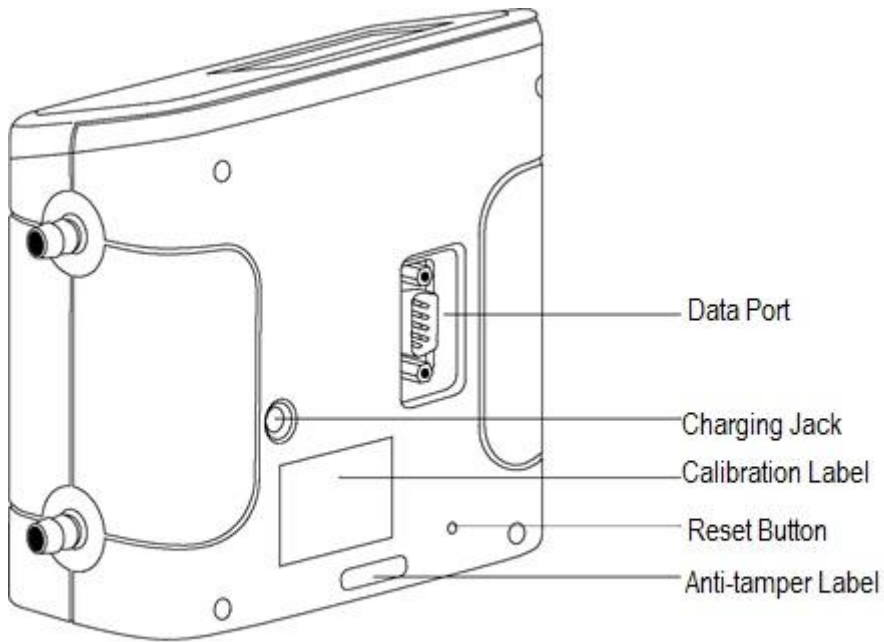
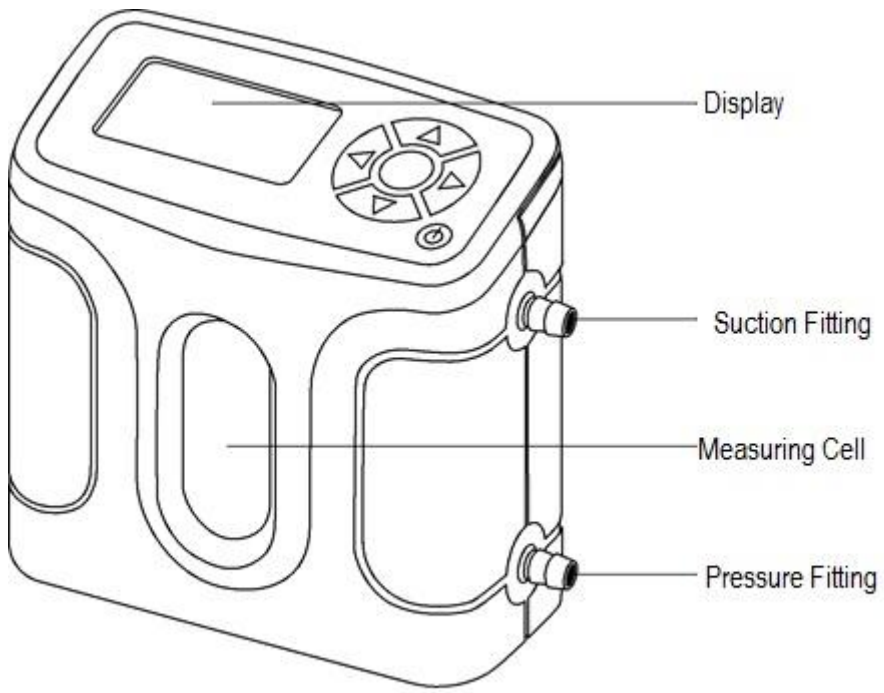

# Chapter 2: Operation

## Battery

### Charging, Installing and Monitoring Your CalTrak Battery

Your CalTrak battery is charged at the factory, but we recommend that you make sure it is fully charged before initial use.

- Connect the AC power adapter to the CalTrak's Charging Jack (DC In).
- Plug the AC power adapter into an AC outlet.

Initial charging should take about eight (8) hours. After the initial charge:

- You may continue to charge your CalTrak indefinitely simply by leaving it connected to the AC power adapter.
- Be sure to charge the battery at least every three (3) months, to maintain battery life.

The battery symbol on the LCD display indicates your CalTrak's battery charge condition. A shaded battery icon indicates a full charge. As the battery voltage drops, the indicator will empty in 20% increments.

	<p><b>Important!</b></p> <p>In compliance with the European Union CE directive 2006/66/EC the battery in your CalTrak should be removed for recycling prior to disposal of the CalTrak. The battery in the CalTrak is a valve regulated sealed lead acid battery. Please note that opening the CalTrak may damage connections so this procedure should only be used for battery disposal.</p>
--	---

## Disposal

In compliance with the European Union CE directive 2006/66/EC the battery in your CalTrak should be removed for recycling prior to disposal of the CalTrak. The battery in the CalTrak is a valve regulated sealed lead acid battery. Please note that opening the CalTrak may damage connections so this procedure should only be used for battery disposal.

## Procedure

Remove five Phillips head screws on the back of the CalTrak; one will be located under the calibration void label. Lift off the rear cover and disconnect the two pin connector from the battery to the printed circuit board. Lift the battery from the case.

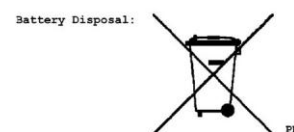
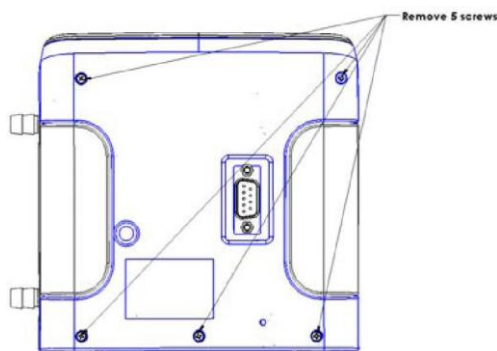



## Activation

### Turning Your CalTrak On and Off...Simply Press The Power Button

- Press the **On/Off** button for 1 second to turn on your CalTrak.
- When first turned on, your CalTrak displays an opening screen showing the product name, model number and flow range.
- Press the **On/Off** button for 3 seconds to turn your CalTrak off.

## Connections

### Attaching Your CalTrak to a Device

Connect device to be calibrated to the appropriate CalTrak port. Use 1/4 inch diameter tubing.

- Connect to outlet at top (suction fitting) when a device draws air (such as sampler).
- Connection tubing to bottom inlet for devices that push air in (pressure devices).

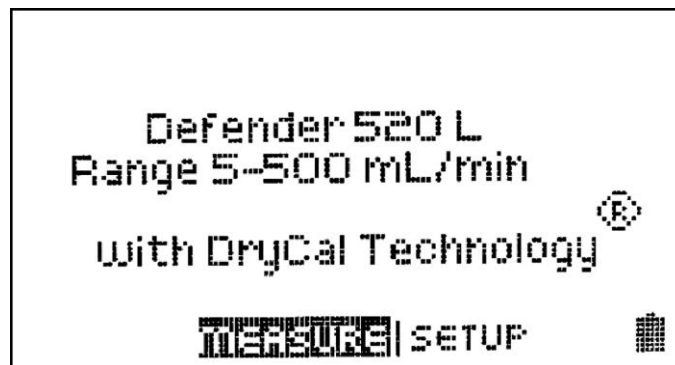

## Display Screen

### Understanding the Screen Components

The CalTrak provides a menu of operational settings and commands. The four directional arrow buttons on the control panel allow you to navigate through the menu and select the desired settings for your CalTrak. Your location within the menu is highlighted for easy identification.

## Menu Navigation

### Moving through operational menus

- Use the directional arrows  $\curvearrowright$ ,  $\curvearrowleft$ ,  $\rightarrow$  and  $\leftarrow$  on the control panel to find your way through the menu.
- When your desired command is highlighted, simply press the **Enter** button on the control panel.

If you see a menu selection within angle brackets (<....>), that means you have multiple options for an item. Press the left or right ( $\leftarrow$  or  $\rightarrow$ ) arrow button to see the options.

Note: If you wish to use the factory settings proceed to “**Measurements, Taking Gas Flow Readings**” section on page 14.

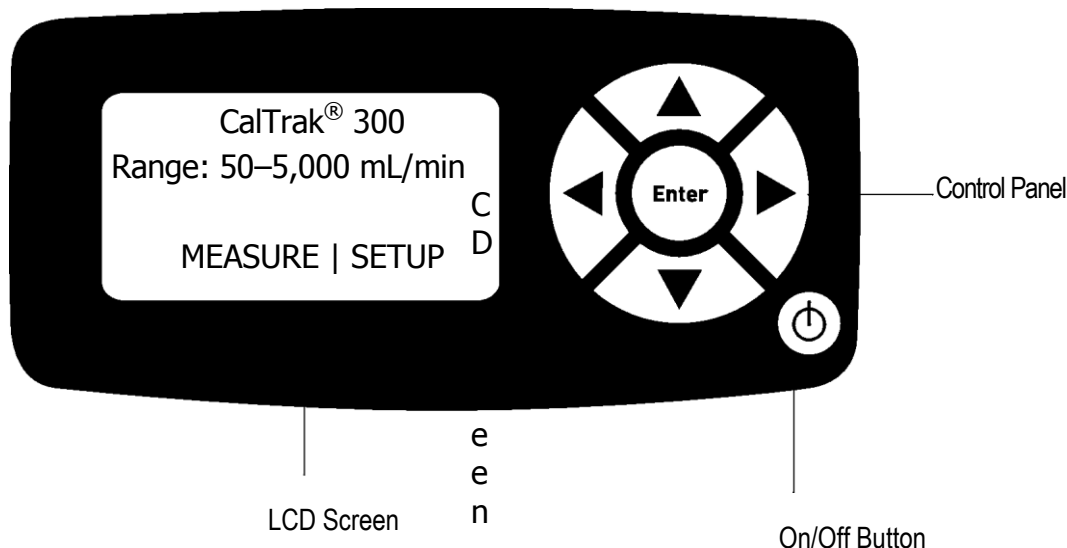

## Set-Up

### Customizing the CalTrak to Your Needs

You can customize your CalTrak in the Setup menu.

Highlight **SETUP** in the introduction screen to enter the Setup Menu. Or, highlight **SETUP** after resetting and then exiting a measurement mode screen. The Setup menu has eight submenus.

To select a submenu, use the directional arrow buttons to highlight the submenu and press the **Enter** button.

In submenus, brackets (i.e., <...>) indicate different selection options. You can switch back and forth by pressing the forward or backward (◀ or ▶) arrow.

Highlight **CONFIRM** after making changes and press the **Enter** button to save the changes made.

‘**Confirmed, New Settings Will be Retained**’ message will appear in the screen for a brief period before it returns to Setup menu.

Highlighting **EXIT** and then pressing the **Enter** button will return you to the **SETUP** menu without saving any submenu changes.

### Readings

Choose the number of measurements in the average from 1 to 100.

If you wish to incorporate a time delay between consecutive measurements, set **Time Between** from 1 to 60 minutes.



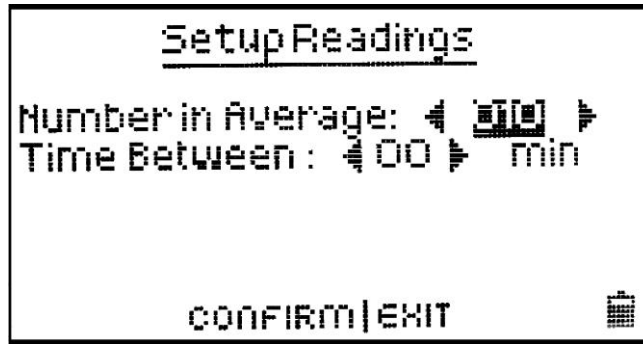

### **Units**

Measure gas Flow in **cubic centimeters, milliliters, liters or cubic feet** (all units are per minute).  
In the CalTrak 300, measure Pressure in mmHg, kPa or PSI and Temperature in Celsius or Fahrenheit.

### **Time**

Set the current time and the format.  
The format can be selected as **PM, AM, or 24H**.

### **Date**

Set the date and the format.  
The format can be selected as **DD (day)-MM (month)-YYYY (year)** or **MM (month) DD (day)-YYYY (year)**.



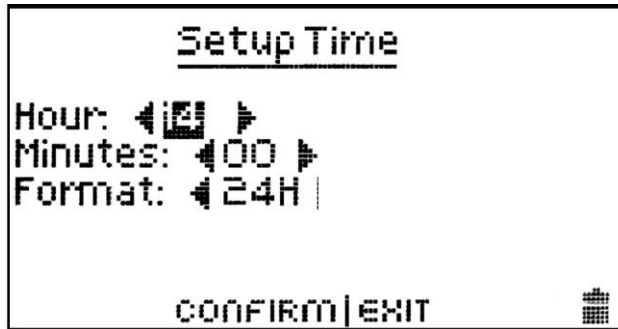

## **Preferences**

### **Read Default**

Select preferred mode of measurement when the CalTrak is initially turned on.

### **Default Settings**

Select <No> to allow the 'Read Default' change. Selecting <Yes> will reset your CalTrak to the factory default settings. (Factory default settings are provided elsewhere in this manual.)

### **Data Port**

Set the data port interface by selecting:  
<SIERRA> to operate with CalSoft™ Software.

### **Magnification**

In the CalTrak 300, this controls the amount of data on the display. Select <Zoom> to view only flow measurements in larger font, or select <Detail> to simultaneously view flow measurements, temperature, and pressure in a smaller font.

## Power

### Power Save

By selecting <On>, your CalTrak will save power by turning off after five minutes of inactivity. However, it will not turn off when connected to the AC power adapter/charger.

Select <Off>, and your CalTrak will remain on until you manually turn it off.

### Backlight

Select <On> to illuminate the LCD display or <Off > to conserve battery power.



## Diagnostics

The CalTrak Leak Test is designed only to verify the internal integrity of the instrument and alert you to an internal leak. We recommend performing the leak test only as an intermediate quality control check or whenever the integrity of the instrument is questioned due to misuse or accidental damage.

Please note that a leak test is not a substitute for a comprehensive examination of the unit's overall performance and it does not ensure that your CalTrak is operating accurately.

- Invert your CalTrak and allow the piston to travel to the top.
- Cap the port under test using the supplied cap. Leave the other port uncapped.
- Press Enter on the control panel while the unit is still inverted.
- Return the unit upright. The leak test will progress.
- If CalTrak leak test is unsuccessful, go to **section 10 Troubleshooting**.
- When test is complete, select exit to return to main menu.

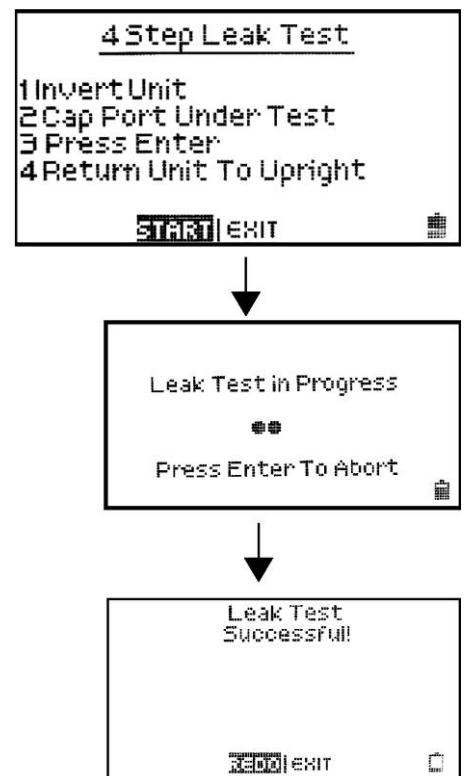



### **Out of Range**

If the flow you are measuring is outside the CalTrak's flow range, (see section 7 CalTrak Specifications for ranges), the "Out of Range!" warning appears. Immediately lower or disconnect the flow. When the flow is within the proper range, select RESET to clear your CalTrak's last measurement.

## **Measurements**

### **Taking Gas Flow Readings**

To maintain the best possible accuracy and minimize thermal effects, Sierra recommends fully charging your battery before taking measurements. If this is not possible, we recommend disconnecting your CalTrak from its AC power adapter/charger while taking flow measurements — or to run gas through your CalTrak for 10 minutes before starting the flow measurement.

### **First Steps**

Press the power button.

- Press the **On/Off** button for 1 second to turn on your CalTrak.
- When first turned on, your CalTrak displays an opening screen showing the product name, model number and flow range.
- Press the **On/Off** button for 3 seconds to turn your CalTrak off.

Connect device to be calibrated to the appropriate CalTrak port. Use <sup>1</sup>/<sub>4</sub> inch diameter tubing.

- Connect to outlet at top (suction fitting) when a device draws air (such as sampler).
- Connect to inlet at bottom (pressure fitting) when a device pushes air.
- Do not cap the unused port on the CalTrak.
- Choose the measurement type, Single, Burst, or Continuous, then press enter.



### **Single Measurement**

Each time the 'Enter' button is pressed, one measurement will be made. When each subsequent measurement is made, the current flow and average of all prior readings will be displayed.

### **Burst Measurement**

This setting functions in the same manner as 'SINGLE', but measurements continue automatically until the preset number of measurements has been made. Operation then ceases, and the last reading and average are displayed.

Press 'Enter' again to begin another preset sequence.

## Continuous Measurement

This setting functions in the same manner as 'BURST', but new sequences will automatically repeat until stopped by the user.

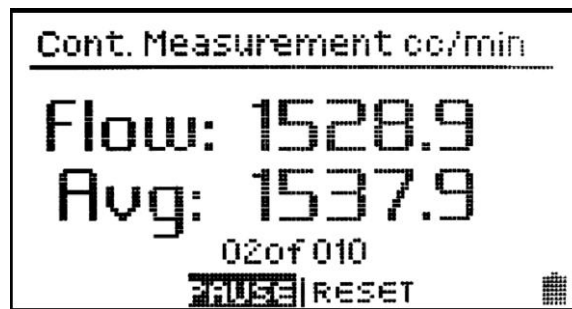

### Note

(010 in series) indicates the number of measurements. 10 is the factory-preset number. Define the number of measurement you prefer, from 1 to 100, by accessing the SETUP menu.

In Continuous or Burst mode, select:

- **PAUSE** to terminate the current flow measurement but to leave the average flow measurement and previous flow measurement on the screen. This allows you to resume the flow measurement sequence if you wish to do so.
- **RESET** to terminate the flow measurement and clear the screen.

# Chapter 3: Data Port, Software & Firmware Upgrades

## ***Interfacing with CalSoft Software***

Your CalTrak comes with a data port that provides a digital Interface for use with Sierra CalSoft software. Visit <http://www.sierrainstruments.com/products/calsoft.html> to learn more about CalSoft and to for access to available CalSoft or CalTrak firmware upgrades.

## ***CalSoft Software***

Sierra's CalSoft software captures flow data from your CalTrak directly to a Microsoft Excel<sup>®</sup> pre-configured spreadsheet.

CalSoft software captures flow data from your CalTrak directly to a pre-configured table.

CalSoft Software System Requirements:

- Windows<sup>®</sup> XP, Windows<sup>®</sup> 7
- Microsoft Excel<sup>®</sup> 2003 and up
- RS-232 port, or if your PC does not have an RS-232 port you will need a USB to RS-232 adapter

## ***CalTrak Firmware Upgrades***

The CalTrak firmware is upgradable through the Data Port. Firmware upgrades and procedures for your CalTrak are available online through our website ([www.sierrainstruments.com](http://www.sierrainstruments.com)).



# Chapter 4: Annual Maintenance and Calibration

## ***Assuring Top Performance and Accuracy***

Your CalTrak is a precision measuring standard with moving parts machined to extremely close tolerances. Various environmental factors, product wear, drift of sensors, or inadvertent damage may adversely affect your CalTrak's measurement accuracy or general performance. For these reasons, Sierra highly recommends having your CalTrak annually verified by our ISO 17025–accredited laboratory to ensure its measurement integrity.

For the ultimate in CalTrak maintenance and to take advantage of any available software and mechanical upgrades, Sierra offers an annual non-mandatory Recertification program. This is a service package that provides complete product refurbishment, testing and available upgrades; calibration and NIST-traceable calibration certificates.



### **Recommended Calibration Recertification Interval**

It is recommended that the instrument be recalibrated and recertified on an annual basis.

**Recertification includes a 90-day service warranty should any related labor or parts replacements prove faulty.**

Turnaround time is generally two weeks from time of receipt. Expedited **48-hour** turnaround is available. To obtain current Recertification pricing, please contact Sierra at **800.866.0200**, or visit our web site at [www.sierrainstruments.com](http://www.sierrainstruments.com). Please contact us to see if expedited service is available for an additional charge.

# Chapter 5: Returning Instrument

## Returning Equipment to Factory

If you are sending in your CalTrak for repair or evaluation (rather than elective re-certification), contact Sierra for technical support or troubleshooting assistance prior to shipping the unit. Provide us a detailed description of your issues. If we are unable to resolve the situation by phone or email, we will issue you an RMA (return merchandise authorization) number. Follow the instructions for returning your instrument for service as noted below.



### RMA Note – Returning Unit for Service

Sierra will not evaluate or service your instrument without an RMA number. Go to <http://www.sierrainstruments.com/rma> to complete an RMA.

## Shipping

When shipping your CalTrak, be sure to follow some simple guidelines to avoid costly damage to your property.

- Pack your instrument carefully. Use adequate packing material. Whenever possible, use the original packing and foam or bubble wrap that came with your CalTrak (packing peanuts NOT recommended). Or use a Sierra CalTrak Pelican carrying case, which provides a hard case shell for protection of your valuable equipment. If you do not already have a Pelican case, visit us at [www.sierrainstruments.com](http://www.sierrainstruments.com) for more information on obtaining one.
- **Include a copy of the RMA form (complete with Sierra supplied RMA number) with the unit(s).**
- Use a major freight carrier (e.g., FedEx, UPS) that supplies tracking numbers.
- Insure your CalTrak. Sierra is not responsible for damage occurred during transit.
- Understand our mutual shipping obligations. Sierra is responsible for shipping cost only if the issue is product related and the CalTrak is still under warranty.

Ship the unit(s) to the following address:

**Sierra Instruments, Inc.  
Attention: Factory Service Center  
5 Harris Court, Building L  
Monterey, CA 93940 USA  
RE: RMA# (your number)**

# Chapter 6: Storage

## ***Protecting Your CalTrak When Not In Use***

If you need to store your CalTrak for an extended period, please follow these guidelines:

- Always store it in a clean, dry place.
- If possible, leave it attached to its AC power adapter/charger while in storage.
- If your CalTrak cannot be attached to its AC power adapter/charger while in storage, please do the following:
  - Fully charge it before extended storage. If the battery is not fully charged prior to storage, it might be permanently damaged.
- Fully charge it at least once every three months.
- Recharge the battery for at least 8 hours prior to reusing your CalTrak after storage.

# Chapter 7: Product Specifications

## Technical data about your CalTrak

### WHY PRIMARY STANDARD?

The CalTrak 300 is a true primary standard in every sense of the word, because its accuracy is based upon primary SI units: the interior diameter of the glass measuring cylinder; the length of piston travel within the cylinder; and the time it takes the piston to travel this distance, implying a known volume. Our patented technology, therefore, offers accuracies at the level of national laboratories in one very compact and portable device.

### PERFORMANCE SPECIFICATIONS

#### Volumetric Flow Accuracy

+/-1.0% of reading

#### Time per Measurement

1 to 15 seconds per reading (approximate)

#### Type

Single (manual), continuous or burst

### OPERATION SPECIFICATIONS

#### Flow Ranges

300-L: 5 ccm to 500 ccm (0.5 L/min)

300-M: 50 ccm to 5,000 ccm (5 L/min)

300-H: 300 ccm to 30,000 ccm (30 L/min)

#### Operating Pressure

15 psia maximum (1.03 barA)

#### Operating Temperature

0°C to 50°C (32°F to 122°F)

#### Ambient Humidity

0–70%, non-condensing

#### Storage Temperature

0°C to 70°C (32°F to 158°F)

#### Flow Modes

Suction or pressure

#### Gas compatibility

Non-corrosive, humidity less than 70% non-condensing

#### Pressure & Suction Fittings

1/4-inch ID barbed tube

#### Volumetric Flow Units

cc/min, mL/min, L/min, cf/min

#### Warranty

1 year; battery 6 months

#### Approvals

RoHS and CE compliant

#### Digital Communication

RS-232 port, or if your PC does not have an RS-232 port you will need a USB to RS-232 adapter

### PHYSICAL SPECIFICATIONS

#### Dimensions

Height: 5.5 inches (140 mm)

Width: 6 inches (150 mm)

Depth: 3 inches (75mm)

#### Weight

29 oz (820 g)

#### Configuration

Integrated flow measuring cell, valve and timing mechanism

### POWER REQUIREMENTS

#### AC Power Adapter/Charger

12VDC, >250ma, 2.5 mm, center positive

#### Battery

6V rechargeable, sealed lead-acid, 6 to 8 hours typical operation

#### Battery Operational Time (5 cycles/min)

3 hours backlight on; 8 hours backlight off

### USER INTERFACE & SOFTWARE

#### Local Interface

Backlit LCD graphical display; Four directional arrow buttons on the control panel allow you to navigate through the menu; user selectable flow units plus time intervals

#### CalSoft™ Software

Software System Requirements

Windows® XP, Windows® 7

Microsoft Excel® 2003 and up

- Captures flow data from your CalTrak instrument for easy export into common software packages, a PC, or Microsoft environment.
- Real-time data monitoring
- Upload the latest version of the firmware to your CalTrak
- Enter flow rates from pumps or other flow source or flow meters and calibrate the flow source.
- Compare the flow measurements from your CalTrak precision calibrator.

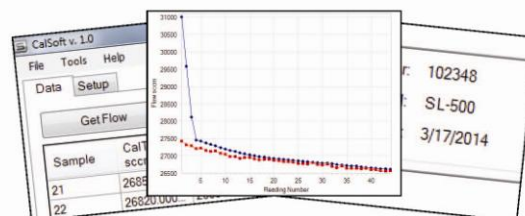

### DIMENSIONS

Front View



### DISPLAY & INTERFACE

Close up of display

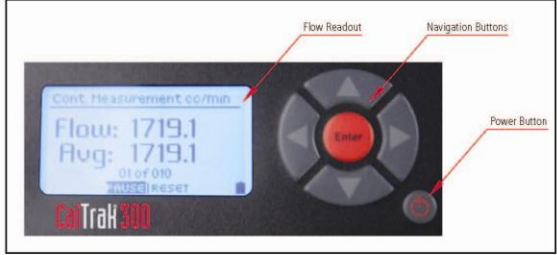

### PRODUCT FEATURES

Front View



Back View



Side View



Parent -

Instructions: To order a CalTrak 300, please fill in each feature number block by selecting the codes from the corresponding features below.

Primary Flow Standard; CalTrak® 300	
300-L	Low flow range, 5 ccm to 50 ccm (0.5 L/min), +/-1.0% of reading (volumetric). Shipment includes a universal 100-240V AC power adapter/charger with U.S. configuration, plastic leak test caps (2), NIST-Traceable calibration certificate, manual
300-M	Medium flow range, 50 ccm to 5,000 ccm (5 L/min), +/-1.0% of reading (volumetric). Shipment includes a universal 100-240V AC power adapter/charger with U.S. configuration, plastic leak test caps (2), NIST-Traceable calibration certificate, manual
300-H	High flow range, 300 ccm – 30,000 ccm (30 L/min), +/- 1.0% of reading (volumetric). Shipment includes a universal 100-240V AC power adapter/charger with U.S. configuration, plastic leak test caps (2), NIST-Traceable calibration certificate, manual

Shop Online - In Stock Product | Ships in one day | In stock model: 300-H | <http://sierrainstruments.com/buycaltrak300>



SIERRA INSTRUMENTS, NORTH AMERICA • 5 Harris Court, Building L • Monterey, California • (800) 866-0200 • (831) 373-0200 • Fax (831) 373-4402 • [www.sierrainstruments.com](http://www.sierrainstruments.com)

SIERRA INSTRUMENTS, EUROPE • Bijlmansweid 2 • 1934RE Egmond aan den Hoef • The Netherlands • +31 72 5071400 • Fax: +31 72 5071401

SIERRA INSTRUMENTS, ASIA • Second Floor Building 5 Senpu Industrial park • 25 Hangdu Road Hangtoun Town • Pu Dong New District • Shanghai, P.R. China 200122 • +8621 5879 8521/22 • Fax: +8621 5879 8586

300 A 03/14

# Chapter 8: Default Settings

## *Original Factory Settings for Your CalTrak*

The CalTrak is set with the following Default settings from the factory:

- Flow Units – mL/min
- Number in Average – 10
- Time Between – 0
- Measurement Mode – Single
- Backlight – On
- Power Save – On
- Time Format – 24 hour
- Date Format – MM-DD-YYYY
- Temperature Units (CalTrak 300 only) – C
- Pressure Units (CalTrak 300 only) – mmHg
- Magnification (CalTrak 300 only) – Zoom

## Chapter 9: Warranty Policy

### **LIMITED WARRANTY POLICY- REGISTER ONLINE**

All Sierra products are warranted to be free from defects in material and workmanship and will be repaired or replaced at no charge to Buyer, provided return or rejection of product is made within a reasonable period but no longer than one (1) year for calibration and non-calibration defects, from date of delivery. To assure warranty service, customers must register their products online on Sierra's website. Online registration of all of your Sierra products is required for our warranty process. Register now at [www.sierrainstruments.com/register](http://www.sierrainstruments.com/register). Learn more about Sierra's warranty policy at [www.sierrainstruments.com/warranty](http://www.sierrainstruments.com/warranty).



# Chapter 10: Troubleshooting

## **Answers to Common Operational Questions**

Sierra is ready to help you with any operational issue you may encounter with your CalTrak. But we may be able to save you some time by providing a short checklist of the questions most commonly asked of our customer service and technical specialists.

### **Why won't my CalTrak turn on?**

If the CalTrak will not turn on, verify that the battery has been charged. When connected to the AC power adapter/charger and power is present a small green indicator light should be visible through the front viewing window

### **My CalTrak won't respond to push-button commands.**

If the CalTrak fails to respond to push-button commands, you can perform a hard reset of the CalTrak. This can be done by inserting a paper clip into the reset opening in the back of the unit.

### **I'm not sure I have my CalTrak connected properly.**

Verify that the flow source is connected to the pressure port of your CalTrak for pressure sources or to the suction port for verifying suction pumps. The unused port should be at atmospheric pressure with any cap or plug removed. If you are calibrating a gas that requires an exhaust line to vent the measurement gas, ensure that the tubing is of sufficient diameter not to create a pressure drop greater than 5 inches of water.

### **How do I protect against leaks?**

Ensure that hose and tube fittings are tight and leak free. The tubing connecting your flow source (pump, mass flow controller, needle valve, sonic nozzle or restrictor) to the meter should be kept as short as possible.

### **What do I do when my leak test fails?**

First check to make sure that the leak test cap is on correctly and it is not leaking through the leak test cap itself. If the leak test cap is correct perform leak test both at the pressure and suction side. If it fails, contact Sierra Technical Support.

### **What's the best way to connect to the filter medium?**

When calibrating sampling pumps best results are obtained with the filter medium connected to the pump and the CalTrak connected to the inlet side of the filter medium with a short piece of tubing.

### **Why am I experiencing a temperature increase in my CalTrak 300?**

A temperature rise during initial battery charging or while charging a fully discharged battery is normal causes of a temperature increase. To maintain the best possible accuracy Sierra recommends fully charging your battery before taking measurements. If this is not possible, we recommend disconnecting your CalTrak from its AC power adapter/charger while taking flow measurements or to run gas through your CalTrak for 1 minute before starting the flow measurement.

### **Why doesn't my piston return to the bottom of the cell?**

If the piston fails to return to the bottom of the cell after a measurement this could be caused by:

- A discharged battery not providing enough power to operate the internal valve properly (Try charging the CalTrak)
- Bright light shining into the unit resulting in an overload of the internal optical sensors (Try to operate the unit in a shaded location)
- Moisture or dirt inside the cell (Return the CalTrak to Sierra for service)

***What is Dead Volume?***

Dead Volume is the gas volume between a flow generator and the instrument taking the measurement. Since gas is compressible, this gas can act as a spring between the flow source and the measurement instrument. For best accuracy this volume should be kept to a minimum.

We recommend keeping the tubing length between the gas flow generator and your CalTrak to no more than .5 meters/20 inches in length.