

Ultra High Purity Immersible Thermal Gas Mass Flow Meter

FEATURES

- The ultra high purity meters are constructed of 316L electro-polished stainless-steel with a 7 to 10 Ra (0.18 to 0.25 Ra (µm)) interior finish
- Direct mass flow monitoring eliminates need for separate temperature and pressure inputs
- Built-in flow conditioner which eliminates velocity-profile distortions caused by upstream disturbances
- Field adjustment of critical flow meter settings via on-board switches or Smart Interface™ (RS-232)
- Field validation of flow meter calibration
- Outstanding rangeability
- One-second response to changes in flow rate
- FM, CSA and ATEX certified for hazardous areas
- CE approved
- PED available
- Digital Communications: Modbus

Ultra High Purity 780S



DESCRIPTION

Sierra Instruments' ultra high purity (UHP) 780S immersible thermal gas mass flow meters are the instruments of choice for gas distribution service in semiconductor fabs, pharmaceutical production and other ultra-clean processes. UHP meters are constructed of 316L electro-polished stainless-steel with a 7 to 10 Ra interior finish.

The versatile microprocessor-based transmitter integrates the functions of flow-range adjustment, meter validation and diagnostics in either a probe-mounted or remote housing. Mass flow rate and totalized flow, as well as other configuration variables, are displayed on the optional 2 x 12 LCD display. The programmable transmitter is easily configured via an RS-232 communication port and Sierra's Smart Interface™ software, or via the display and magnetic switches on the instruments display.

The 780S smart electronics allow you to easily configure the following performance parameters: flow range, reset totalizer, alarm settings, time response, low flow cut-off and a calibration correction factor. The Smart Interface™ also allows for field validation of flow meter performance and calibration.

The 780S has a built-in flow conditioning which eliminates velocity-profile distortions caused by upstream disturbances.

The meter is FM, CSA, ATEX and PED approved for operation in hazardous areas and is available with a variety of input power, output signal, mounting and packaging options.



www.sierrainstruments.com



DIMENSIONAL SPECIFICATIONS

1 Through 6-inch 780S UHP (E2)

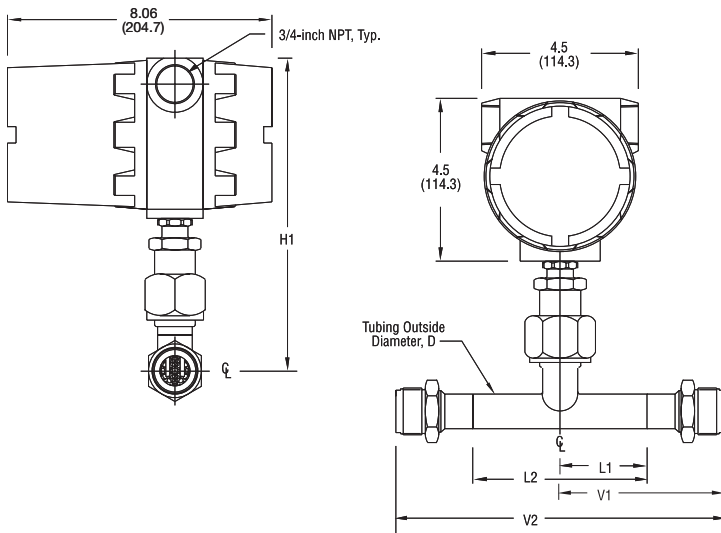

780S Uhp Dimensions							
TUBING SIZE	GENERAL		BUTT WELD		VCR		TUBE WALL
	H1	H2	L1	L2	V1	V2	
.375 (9.5)	10.30 (262)	10.20 (259)	2.98 (72.4)	5.70 (144.8)	3.48 (88.4)	6.96 (176.8)	.035 (0.9)
.500 (12.7)	10.40 (264)	10.20 (259)	2.90 (73.7)	5.80 (147.3)	4.00 (101.6)	8.00 (203.2)	.049 (1.2)
1.00 (25.4)	9.10 (231.1)	9.20 (234)	2.50 (63.5)	5.00 (127)	4.72 (119.9)	9.44 (239.8)	.065 (1.7)
1.50 (38.1)	9.10 (231.1)	9.30 (131.3)	2.00 (50.8)	5.50 (139.7)	—	—	.065 (1.7)
2.00 (50.8)	10.90 (276.9)	10.80 (183.1)	2.50 (63.5)	7.00 (177.8)	—	—	.065 (1.7)
3.00 (76.2)	10.70 (271.8)	10.90 (178.1)	3.00 (76.2)	10.50 (226.7)	—	—	.065 (1.7)
4.00 (101.6)	10.70 (271.8)	10.90 (277)	4.00 (101.6)	14.00 (355.6)	—	—	.083 (2.1)
6.00 (152.4)	12.70 (322.6)	11.90 (302)	6.00 (152.4)	21.00 (533.4)	—	—	.109 (2.8)

REMOTE 780S UHP SPECIFICATIONS

Remote Mounted with Junction Box (E4)

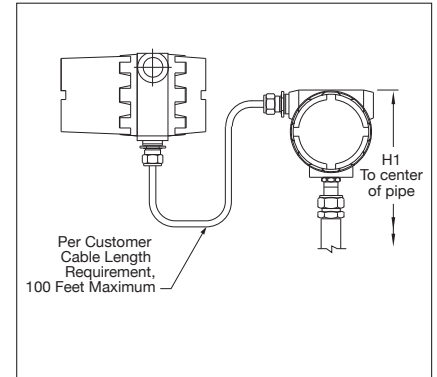

NEMA 4X Remote Mounted with Junction Box (EN4)

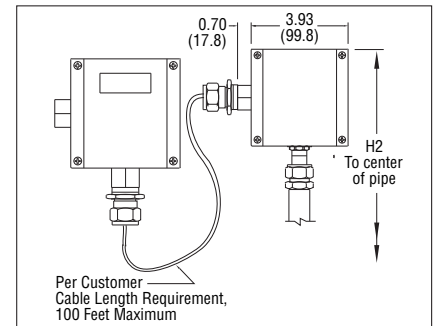

3/8 & 1/2-inch 780S UHP—Side View (EN2)

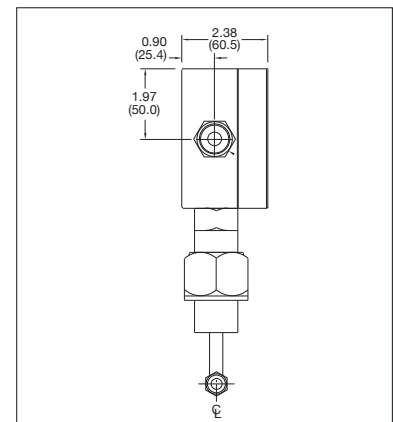

3/8 & 1/2-inch 780S UHP—Front View (EN2)

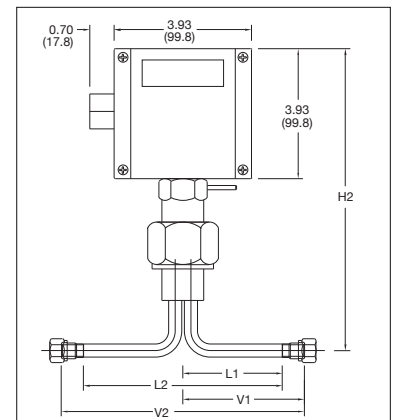

Up Stream Straight Pipe Length Requirements(1) At 1 Atm		
PIPING CONDITION	3/8 AND 1/2-INCH 780SUHP ⁽²⁾	1 TO 6-INCH 780SUHP ⁽⁴⁾
Single 90° Elbow or T-Piece	1D	1D
Reduction (4:1)	1D	3D
Expansion (4:1)	3D	3D
After Control Valve	3D	3D
Two 90° Elbows (In Same Plane)	3D	3D
Two 90° Elbows (Different Planes)	5D	5D

- Notes: (1) Number of diameters (D) of straight pipe required between upstream disturbance and the flow meter.
- (2) Requires 1D of straight pipe downstream of the flow meter.
- (3) Requires 3D of straight pipe downstream of the flow meter.
- (4) Requires 0D of straight pipe downstream of the flow meter.
- (5) Consult factory for pressure effect.

PERFORMANCE SPECIFICATIONS

Accuracy

+/- 1% of reading + 0.5 % of full scale

Repeatability

+/- 0.2% of full scale

Temperature Coefficient

+/- 0.02% of reading per °F within +/- 50° F of customer specified conditions

+/- 0.03% of reading per °F within +/- 50° F to 100° F of customer specified conditions

+/- 0.04% of reading per °C within +/- 25° C of customer specified conditions

+/- 0.06% of reading per °C within +/- 25° C to 50° C of customer specified conditions

Pressure Coefficient

.02% per psi for air, consult factory for other gases

Response Time

One second to 63% of final velocity value

OPERATING SPECIFICATIONS

Gases

Argon, helium, hydrogen, nitrogen, oxygen (consult factory for other gases)

Gas Pressure

Mechanical design pressure:

500 psig (34.5 barg)

Gas & Ambient Temperature

Gas -40° F to 250° F (-40° C to 120° C)

Ambient -40° F to 120° F (-40° C to 50° C)

Leak Integrity

5 X 10⁻⁹ cc/sec of helium maximum

Power Requirements

18 to 30 VDC (regulated), 625 mA maximum

100 to 240 VAC, 50/60 Hz, 15 watts maximum

Output Signal

Linear 0–5 VDC or 0-10 VDC proportional to mass flow rate,

1000 ohms minimum load resistance or

Linear 4–20 mA proportional to mass flow rate,

700 ohms maximum resistance power supply dependent User-selectable.

Active non-galvanically separated or passive galvanically separated (loop powered)

See Digital Communications options below

Alarms

Hard contact user-adjustable high and low

Dead band adjustable with Smart Interface™ software

Relay ratings: Maximum 400 VDC or VAC (peak), 140 mA

Displays

Alphanumeric 2 x 12 digit backlit LCD

Adjustable variables via on-board switches (password protected)

or with Smart Interface™ software

Adjustable variable; Full scale (50 to 100 %)

Time Response (1 to 7 seconds)

Correction factor setting (0.5 to 5)

Zero and span

Totalizer

Seven digits (9,999,999) in engineering units

Resettable by software, on-board switches or external magnet

SOFTWARE

Smart Interface™ Windows®-based software

Minimum 8 MB of RAM, preferred 16 MB of RAM

RS-232 communication

Additional features: Alarm dead band adjustment

Zero cut-off adjustment

Linearization adjustment

Save / Load configurations

Flow meter validation

DIGITAL COMMUNICATIONS

Pulse (not available with E2-NR)

Modbus RTU (not available with P3 option)

PHYSICAL SPECIFICATIONS

Wetted Materials

316L stainless steel

UHP: 7 to 10 Ra internal finish

Enclosure

Hazardous-Area location enclosure (IP66) or NEMA 4X (IP65)

Both are powder-coated cast aluminum

Electrical Connection

Two 3/4 inch NPT . . . Hazardous-Area location enclosure (IP66)

One 1/2 inch NPT . . . NEMA 4X Enclosure (IP65)

Certifications

CE

CSA (Explosion proof for Class I, Division 1, Groups B, C, D)

ATEX (II 2 GD Ex d IIC T6 ... T2; IP 66 T70 °C ... T280 °C)

FM (Explosion proof for Class I, Division 1, Groups B, C, D; dust-ignition proof for Class II, III, Division 1, Groups E, F, G)

IP65, NEMA 4X T6 -40° C to 70° C ambient

PED optional

PRESSURE DROP

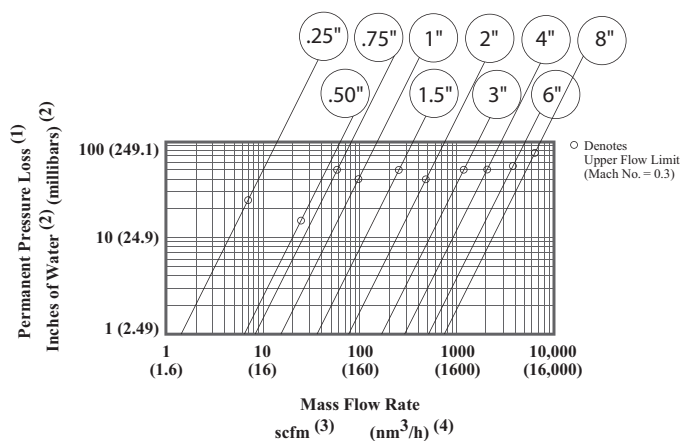

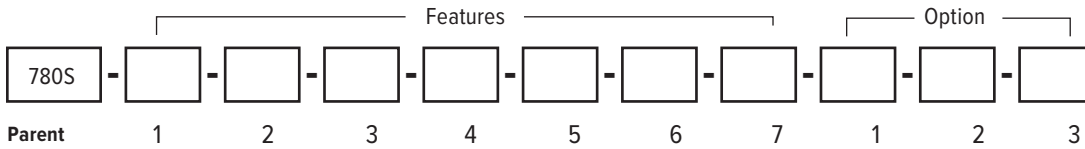

Instructions: To order a 780S UHP please fill in each number block by selecting the codes from the corresponding features below and following pages.

Parent Model Number	
780S	Ultra High Purity In-Line Mass Flow Meter with built-in flow conditioner

Note: The following lists standard product/pricing. Sierra will work with you for special requests. Please submit your request using the RFQ/Specials tab in this price list.

Feature 1: Approvals	
NAA	Non-agency approved meter
ATEX	780S with II 2 GD Ex d IIC T2...T6 ATEX Approval. Requires E2 or E3 enclosure. Note: ATEX units have circuit energy limitations that limit maximum flows to approx. 50% of non-ATEX units. Consult gas tables for details.
FM	780S with FM approval. Requires E2 or E4 enclosure
CSA	780S with CSA approval. Requires E2 or E4 enclosure

Feature 2: Body Size UHP			
UHP-BW1	UHP 0.375 inch tube O.D. butt weld prep	UHP-VCR4	UHP 1 inch tube O.D. male VCR fittings
UHP-VCR1	UHP 0.375 inch tube O.D. female VCR fittings	UHP-BW5	UHP 1.5 inch tube O.D. butt weld prep
UHP-BW2	UHP 0.50 inch tube O.D. butt weld prep	UHP-BW6	UHP 2 inch tube O.D. butt weld prep
UHP-VCR2	UHP 0.50 inch tube O.D. female VCR fittings	UHP-BW7	UHP 3 inch tube O.D. butt weld prep
UHP-BW4	UHP 1 inch tube O.D. butt weld prep	UHP-BW8	UHP 4 inch tube O.D. butt weld prep

Feature 3: Electronics Enclosure	
E2	Hazardous-area location enclosure (IP66). Mounted directly on probe
E3 ()	Remote probe and flow body 10, 25, 50, 100 feet (select one) away from the probe
E4 ()	Remote Hazardous-Area Location Enclosure (IP66) with Junction Box.
EN2	NEMA 4X (IP65) Enclosure. Mounted directly on probe.
EN4 ()	Remote NEMA 4X (IP65) Enclosure with Junction Box.

Note: E4, EN4: 10, 25, 50, 100 feet (select one) away from the probe with junction box mounted on probe.

Note: Customer may cut cable length with no effect on accuracy.

Feature 4: Input Power	
P2	18–30 VDC
P3	100–240 VAC. Not available with EN enclosures.

Feature 5: Output	
V1	0–5 VDC, linear
V3	0-10 VDC, linear
V4	4-20 mA, linear

Feature 6 : Display	
NR	No Readout
DD	Digital display. 2 x 12 digit, backlit, LCD display indicates flow rate and totalized mass in engineering units. Simplifies configuration settings and provides system status information
DD-NRT	Totalizer cannot be reset in the field.

Feature 7: Gas	
0	Air
1	Argon
2	Carbon dioxide
3	Chlorine ¹
4	Digester gas
5	Digester gas ¹
6	Helium
7	Hydrogen
8	Methane
9	Methane ¹
10	Nitrogen
11	Oxygen ¹
12	Propane
13	Propane ¹
14	Ammonia ¹
99	Other--Consult Factory Gas Table

¹Correlation calibration - consult Gas Table for accuracy.
 Note: Consult Product Data Sheet for flow rate, pressure, and temperature limits.

Option 1: Digital Communications	
Pulse	Totalizer pulse output (Only available with E2/E3/E4 enclosures WITH DD. Available on ALL EN2 Enclosures)
MB	Modbus RTU with full device description (P2 only); ATEX and FM approvals available

Note: All except Pulse require DC power (P2).

Option 2: Certificates	
MC	Material certificates--US Mill certs on all wetted parts
PED	Manufactured according to PED directive
CC	Certificate of conformance
NACE	NACE certificate for sour gas
LT	Leak test certificate
PT	Pressure test certificate
CO	Stamped Certificate of Origin

Option 3: O2 Cleaning	
O2C	O2 Cleaning. Meters up to 4 inches (DN100). Includes certification. Product cleaned for O2 service. Inspected with Ultra-Violet light, double-bagged prior to shipment.

Note: Consult factory for O2 Cleaning of meters over 4-inches (DN100).



Measurably Different™



Sierra Instruments

North America
5 Harris Court, Building L
Monterey, California 93940
+1.831.373.0200 • sierrainstruments.com

EMEA
Bijlmansweid 2
1934RE Egmond aan den Hoef • The Netherlands
+31 72 5071400 • Fax: +31 72 5071401

Asia
Second Floor Building 5 • Senpu Industrial Park • 25 Hangdu
Road Hangtoun Town • Pu Dong New District • Shanghai, P.R.
China 201316 • +8621 5879 8521/22 • Fax: +8621 5879 8586