

TM500[™]

High Performance Industrial Thermal Mass Flow Meter



DATA SHEET



Built to Tell the Truth

Whether you're a facilities manager or a process, energy, or environmental engineer, the questions are the same. Are the flow measurements you're getting for your system accurate and reliable? How quickly can you make necessary adjustments in the field that you can depend on?

The Sierra TM500™ promises precision, speed, and the field flexibility you need to adjust gas mixes and configure meter settings to maintain optimum process efficiency. Designed for the most demanding industrial processes in facilities management, chemical plants, gas refineries, and petrochemical production, Sierra flow measurement instruments are built to last and meet your application, budget, and delivery needs.

The TM500 makes you smarter and your processes more reliably efficient. And we're always here if you need us—Sierra's promise to customers for 50 years.

Why Thermal?

Sierra's thermal technology delivers direct measurement of gas mass flow. Unlike differential pressure (dP) meters that measure volumetric flow, it's simpler to make and maintain, and no temperature or pressure corrections are required. dP requires additional calculations to convert volumetric flow to mass flow, the measurement that most often needs to be reported. That reduces accuracy. Thermal has no pressure drop or flow restrictions, significantly reducing expense once the full ownership cost is considered.

Continued pg 4

Precision

- Accuracy
 - +/- 1.0% of reading plus +/- 0.2% of full-scale – Air, Nitrogen
 - +/- 1.5% of reading plus +/- 0.5% of full-scale – All other gases
- Repeatability +/- 0.2% of full scale
- Direct measurement of gas mass flow / No volume to mass calculations
- DigiSense™ robust sensor design
- Welded, 316 SS sensor
- Insertion, Inline, and Remote styles
- Rotatable enclosure: allows +/-180 degree display orientation
- AC or DC power input options
- Velocity Range: 0 to 45,000 sfpm
- Wide measurement range: up to 1000:1 turndown; 100:1 typical
- Negligible pressure drop
- Two 4-20mA outputs for flow rate and temperature
- Measure gas flow rate in scfm, mcf/d, kg/h, and more
- Low-end sensitivity (0-500 sfpm) for leak detection and other low-flow applications
- Communication options: HART or Modbus RTU (RS485)
- FM/FMc, ATEX, IECEx, and UKEX approvals
- NEMA 4X and CE Mark

Field Flexibility

- Microprocessor based, field programmable electronics
- Menu of field selectable gas compositions with Gas-Mix™ Option
- Free TM500-View™ software available / USB port connects to a PC
- Calibration Validation with TM-Cal™
- NIST-traceable calibration

Delivery

- 2 to 3 week lead times are typical after order acceptance
- 1 week or less expedited lead times are available after order acceptance
- Contact Sierra for details

DigiSense™ Sensor

DigiSense is the state-of-the-art sensor technology used in the TM500. Unlike other thermal flow sensors, it interfaces directly with its microprocessor for greater control, precision, and programmability. DigiSense accurately responds to changes in process variables (gas flow rate, pressure, and temperature) to determine mass flow rate, totalized flow, and temperature.

DigiSense's correlation algorithms allow the meter to be calibrated on a single gas in the factory while enabling the user to select other gases in the Gas-Mix menu.



Gas-Mix™ Menu

Gas-Mix allows users rapid gas selection or mixing in the field from a pre-calibrated list of 14 gases. With an onboard 2-line x 16-character backlit display, operators can view flow rate, total, elapsed time, process gas temperature, and alarms. The display is also used with the configuration panel to access flow meter settings, such as 4-20mA and pulse output scaling, pipe diameter, low flow cutoff, flow filtering (damping), display options, and high or low alarm limits.

TM500-View™ Software

Sierra's TM500-View advanced software is a free PC-compatible application available for download from Sierra's website. Connect your Windows-based laptop or PC to the meter using the USB port interface to access data and configure the meter's settings.

TM500-View Features

- Get quick access to all configuration parameters with pop-up windows and pull-down menus
- View raw data to diagnose or troubleshoot your meter
- Select measurement units, flow and temperature ranges, alarm settings, and more
- Print or save a TM-Cal Calibration Validation Certificate
- Set alarms and display alarm codes
- Use simulation mode to align 4-20mA output with the input to the customer's PLC/DCS

TM-Cal™ Calibration Validation

The TM500 includes on-board calibration verification through the TM-Cal feature. This diagnostic is automated and does not require any additional equipment or removal of the TM500 from your process.

TM-Cal takes less than five minutes for completion and can be initiated via the meter's display, Modbus RTU, or TM500-View software. When the test is complete, a pass/fail response indicates if the meter requires troubleshooting or recalibration.

Using TM500-View to run TM-Cal results in a calibration validation certificate that can be printed or saved for compliance with the user's local regulations and metrology requirements. The certificate includes all relevant information from the test – time and date, meter identification, and pass/fail results.

Measurably Different™

Our primary goal at Sierra is to help make your operation smarter and more productive with the precision flow measurement tools we design and build to meet your application, budget, and delivery needs. And with 50 years of expertise, we're always here for you.

Performance Specs

Flow Accuracy

Air and Nitrogen (N₂): +/-1% of reading +/-0.2% of full scale
 Other Gases: ± 1.5% of reading ± 0.5% of full scale.
 Accuracy specification applies to customer's selected flow range
 Maximum range: 15 to 45,000 SFPM (0.07 to 212 NMPS)
 Minimum range: 15 to 500 SFPM (0.07 to 2.4 NMPS)

Straight, Unobstructed Pipe Requirement

- Insertion: 15 diameters upstream 10 downstream
- Inline: 8 diameters upstream, 4 downstream
- Insertion Meters with FlowTrak: 7 diameters upstream; 5 downstream

Gross Heating Value Uncertainty

±0.01% on mass basis; ±1.0% on volume basis;

Flow Repeatability

±0.2% of full scale

Flow Response Time

0.8 seconds (one time constant)

Temperature Accuracy

±1° F (±0.6° C)

Calibration

Factory Calibration to NIST traceable standards

TM-Cal™

In-situ, operator-initiated calibration validation

Operation Specs

Gas Selections

Gas-Mix is an optional feature of the TM500. You can choose from menus of single gases or create custom gas mixtures if purchased.

Single (100%)	*Mixes
Air	Methane
Argon	Carbon Dioxide
Butane	Nitrogen
Carbon Dioxide	Helium
Ethane	Argon
Ethylene	Hydrogen
Helium	Air
Hydrogen	Propane
Methane	Butane
Natural Gas	Oxygen
Nitrogen	Ethane
Oxygen	Ethylene
Propane	Propylene
Propylene	

*Note: 14 gases/ unlimited mixes, mix any number of the 14 gases

Gas Pressure

Maximum gas pressure at 100°F
 Insertion: 740 psig (51 barg)
 316 SS inline w/NPT ends: 500 psig (34 barg)
 316 SS inline w/150lb flanges: 230 psig (16 barg)
 316 SS inline w/300lb flanges: 600 psig (41 barg)

Gas Pressure (continued)

CS inline w/NPT ends: 500 psig (34 barg)
 CS inline w/150lb flanges: 285 psig (20 barg)
 CS inline w/300lb flanges: 740 psig (51 barg)
 Hot-Tap and Ball Valve: 150 psig (10 barg) max

Notes: Check with factory for higher pressure options.
 With Teflon Ferrule option, maximum gas pressure is 60 psig (4.1 barg) maximum.

Pressure ratings stated for temperature of 100°F (38°C).

The EU Pressure Equipment Directive (PED) requires that the minimum ambient and fluid temperature rating for carbon steel flow bodies not be below -29°C.

Temperature

DigiSense™ Sensor: -40°C to 250°F (-40°C to 121°C)
 Enclosure: -40°C to 158°F (-40°C to 70°C)*
 Remote Sensor Enclosure: . . . -40°F to 158°F (-40°C to 70°C)

*NOTE: Display dims below -4°F (-20°C); function returns once temperature rises again.

Flow Velocity Range

15 to 45,000 SFPM (0.07 to 212 NMPS)
 Turndown: up to 1000:1; 100:1 typical

Maximum Flow Ranges for TM500 Insertion Flow Meters

Pipe Diameter	SCFM	MSCFD	NM3/Hr
1.5" (40mm)	0-630	0-910	0-1,000
2" (50mm)	0-1,040	0-1,490	0-1,640
2.5" (63mm)	0-1,490	0-2,140	0-2,350
3" (80mm)	0-2,300	0-3,320	0-3,630
4" (100mm)	0-3,970	0-5,720	0-6,270
6" (150mm)	0-9,020	0-12,990	0-14,230
8" (200mm)	0-15,630	0-22,500	0-24,650
10" (250mm)	0-24,630	0-35,080	0-38,430
12" (300mm)	0-34,980	0-50,370	0-55,180

NOTE: To determine if the TM500 will operate accurately in other pipe sizes, divide the maximum flow rate by the pipe area. The application is acceptable if the resulting velocity is within the velocity range above.

Maximum Flow Ranges for TM500 Inline Flow Meters

Size	SCFM	MSCFD	NM3/Hr
0.75"	0-160	0-230	0-260
1"	0-270	0-380	0-420
1.25"	0-460	0-670	0-730
1.5"	0-630	0-910	0-1,000
2"	0-1,040	0-1,490	0-1,640
2.5"	0-1,490	0-2,140	0-2,350
3"	0-2,300	0-3,320	0-3,630
4"	0-3,970	0-5,720	0-6,270
6"	0-9,020	0-12,990	0-14,230

NOTE: Standard conditions of air at 70°F and one atmosphere. Consult factory for other gases and for flow ranges above those listed. Inline Meters above 2,500 SCFM (3,950 NM3/H) may require third-party calibration. Contact Sierra Instruments.

Operation Specs (continued)

Relative Humidity

90% RH maximum; non-condensing

NOTE: Condensing liquids contacting the sensor can cause erratic flow indication.

Units of Measurement (field-selectable)

SCFM, SCFH, NM3/M, NM3/H, NM3/D, NLPS, NLPM, NLPH, MCFD, MSCFD, SCFD, MMSCFD, MMSCFM, SM3/D, SM3/H, SM3/M, LB/S, LB/M, LB/H, LB/D, KG/S, KG/M, KG/H, SLPM, MT/H

Input Power

12 to 24 VDC $\overline{\text{---}}$, 6 watts

Full input power range: 10 to 30 VDC.

20 Watt or greater power supply is recommended.

100 to 240 VAC, 50-60Hz, 7 watts. Full input power range: 85 to 264 VAC (AC power option).

Class I Equipment (Electrical Grounding Required for Safety).

Installation (Over-voltage) Category II for transient over-voltages.

Inputs/Outputs

4-20mA Channel 1:

Standard isolated 4-20mA output configured to indicate for flow; fault indication per NAMUR NE43. HART communication option.

The 4-20mA Load resistance must be 125 ohms or less on 24 volt power.

4-20mA Channel 2:

Standard isolated 4-20mA output configured to indicate flow or temperature.

Pulse/Alarms

Isolated open collector output rated for 5 to 24 VDC.

20mA maximum load, 0 to 100Hz (the pulse output can be configured to either transmit a 0 to 100Hz signal proportional to flow rate or an on/off alarm).

Remote Switch Input

Can be configured to reset the flow totalizer and elapsed time.

Serial Communication

Isolated Modbus RTU (RS485) option

Isolated HART communication option

USB Communication

Isolated USB 2.0 for interfacing with a laptop or computer is standard.

TM500-View™: A free PC-based software tool that provides complete configuration, remote process monitoring, and data logging functions through USB communication.

4-20mA and Loop Verification:

Simulation mode used to align 4-20mA output with the input to customer's PLC/DCS.

Physical Specs

Sensor Material

316 stainless steel

Enclosure

NEMA 4X (IP67), aluminum, 3/4-inch FNPT conduit entries

Cabling to Remote Enclosure

8-conductor, 18 AWG, twisted pair, shielded, 100 feet maximum

Insertion Flow Meter Installation

Sierra supplied compression fitting connects to customer-supplied 1" branch outlet welded to pipe.

Dimensions

TM500 Insertion Meter

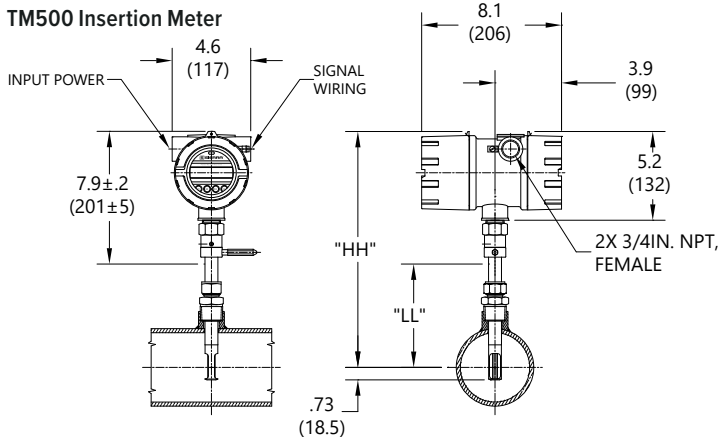

TM500 Insertion Meter with Hot-Tap

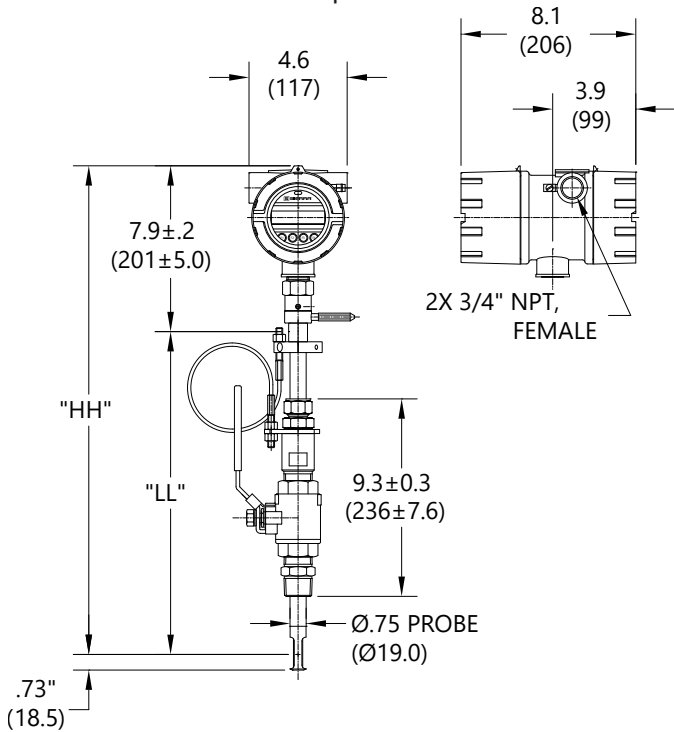

TM500 Insertion Remote Meter

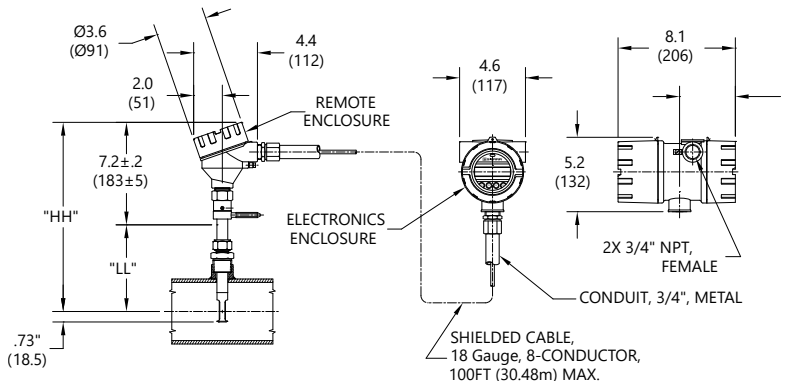

Insertion Styles

Probe Length Options for TM500 Insertion Flow Meters

6.0 (152.4)	18.0 (457.2)
9.0 (228.6)	24.0 (609.6)
12.0 (304.8)	30.0 (762.0)
15.0 (381.0)	36.0 (914.4)

Assuming there is no insulation or hot-tap, Sierra recommends the following probe lengths:

Pipe Size	Probe Length
1.5" (40mm) to 6" (150mm)	6-inch
8" (200mm) to 12" (300mm)	9-inch
14" (350mm) to 18" (450mm)	12-inch

Note: For "HH" and "LL" dimensions, please refer to pages 103-113 in the TM500 Manual.

Equation for Selecting Insertion Flow Meter Probe Length.

Probe length = ½ pipe ID (in inches) + 3" + thickness of insulation (if any) + 10" (for hot-tap if supplied). Round up to the next standard probe length available.

Note: Contact Sierra for longer probes.

Inline Styles

Inline pipe sizes, materials, and end connections are listed in the table below.

Inline pipe sizes in Inches =

0.75	○	●	◐	1.50	○	●	◐	3.00	○	●	◐	◑
1.00	○	●	◐	2.00	○	●	◐	4.00	○	●	◐	◑
1.25	○	●	◐	2.50	○	●	◐	6.00	○	●	◐	◑

Note: TM500 inline flow bodies include built-in flow conditioners. FlowTrak Flow Conditioners are available as an option for TM500 insertion flow meters.

○= SS ●= CS ◐= NPT Ends ◑= 150lb flanges ◒= 300lb flanges

Probe Diameter

Probe diameter 3/4-inch for insertion and inline flow meters.

TM500 Insertion Remote Meter with Hot-Tap

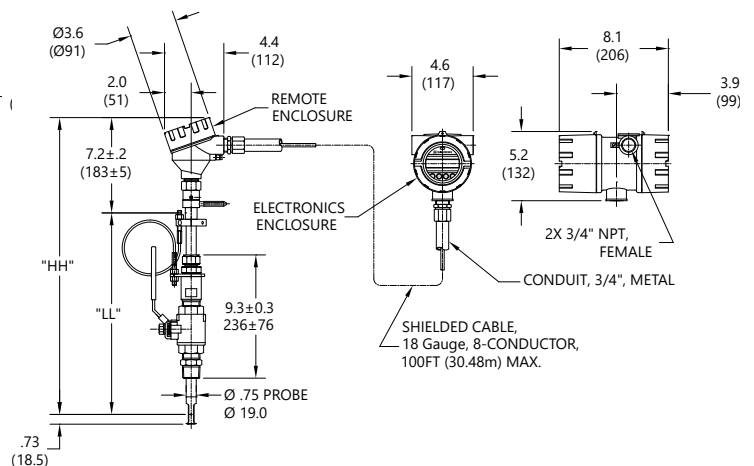

Physical Dimensions Continued

TM500 Inline Meter - NPT

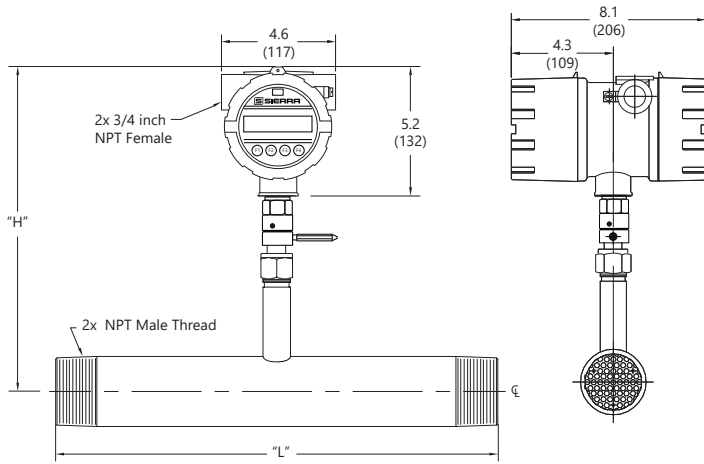

TM500 Inline Remote Meter - NPT

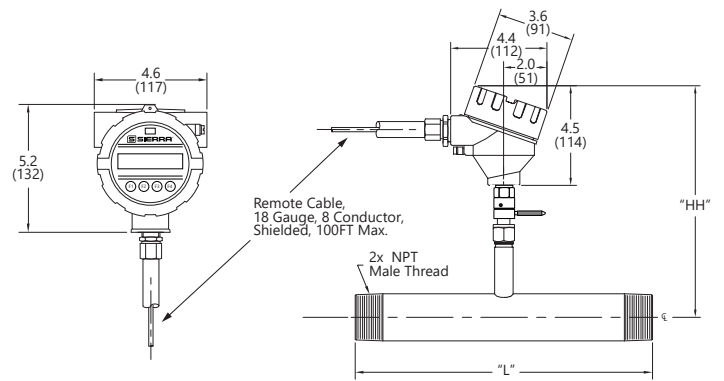

TM500 Inline Meter - 150 lb Flange

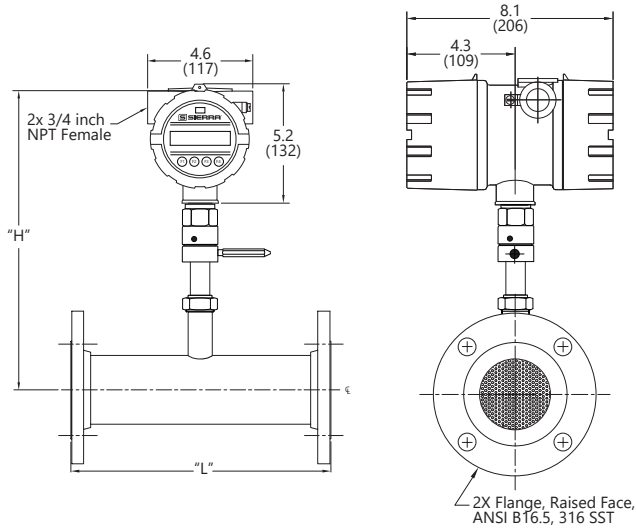

TM500 Inline Remote Meter - 150 lb Flange

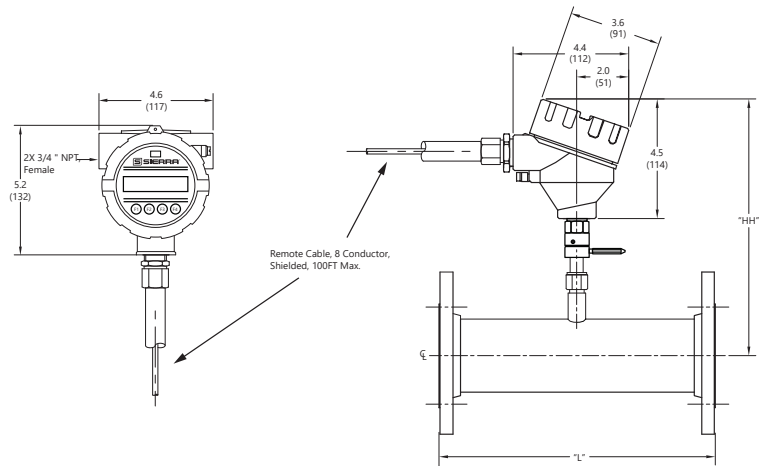

TM500 Inline Meter - 300 lb Flange

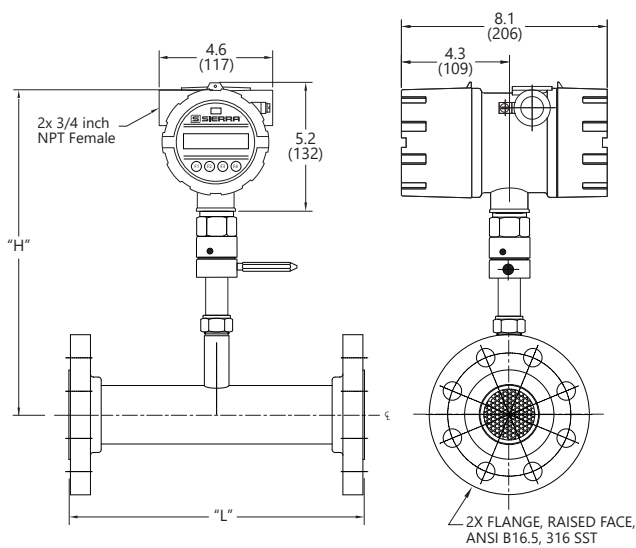

TM500 Inline Remote Meter - 300 lb Flange

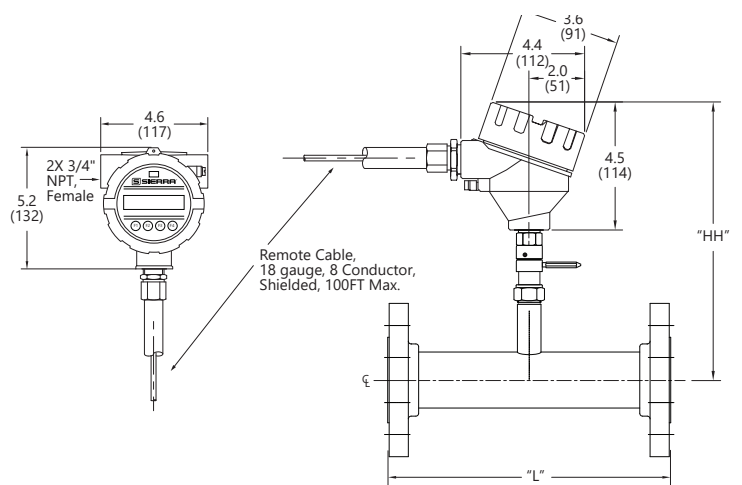

Approvals

CE Mark

EMC Directive: 2014/30/EU
 Electrical Equipment for Measurement, Control and Lab Use: EN61326-1:2013
 Low Voltage Directive (LVD): 2014/35/EU Product Safety Testing: EN 61010-1: 2010
 Pressure Equipment Directive: 2014/68/EU
 Weld Testing: EN ISO 15614-1 and EN ISO 9606-1, ASME B31.3

FM (FM21US0124X) and FMc (FM21CA0090X)

Class I, Division 1, Groups B, C, D;
 Class II, Division 1, Groups E, F, G;
 Class III, Division 1; T6 or T4, Ta = -40°C to +70°C;
 Class I, Zone 1, AEx/Ex db IIB + H2 T6 or T4; Gb Ta = -20°C to 70°C; Type 4X, IP67

ATEX (FM23ATEX0042X)

II 2 G Ex db IIB + H2 T6 or T4 Gb Ta = - 20°C to +70°C; IP67
 II 2 D Ex tb IIIC T85°C or T135°C Db Ta = - 20°C to +70°C; IP67

IECEX (IECEX FMG 23.0020X)

Ex db IIB + H2 T6 or T4 Gb Ta = - 20°C to +70°C; IP67
 Ex tb IIIC T85°C or T135°C Db Ta = - 20°C to +70°C; IP67

UKEX (FM23UKEX0041X)

II 2 G Ex db IIB + H2 T6 or T4 Gb Ta = -20°C to +70°C; IP67
 II 2 D Ex tb IIIC T85°C or T135°C Db Ta = -20°C to +70°C; IP67

ATEX and IECEX Standards

EN IEC 60079-0	EN 60079-31	IEC 60079-0	IEC 60079-31
EN 60079-1	EN 60529 +A1 +A2	IEC 60079-1	IEC 60529

Specific Conditions of Use:

- The flameproof joints of the equipment are not intended to be repaired. Consult the manufacturer if dimensional information on the flameproof joints is necessary.
- Refer to the manufacturer's instructions to reduce the potential of an electrostatic charging hazard on the equipment or enclosure.
- The equipment temperature code ratings are dependent on the enclosure configuration model code (local or remote). Refer to the following table for specific temperature code markings.

Enclosure Model Code	Temperature Code Marking - Division (All)		Temperature Code Marking - Zones (Gas)		Temperature Code Marking - Zones (Dust)	
	Main Enclosure	Remote Enclosure	Main Enclosure	Remote Enclosure	Main Enclosure	Remote Enclosure
E1	T4	N/A	T4	N/A	T135°C	N/A
E2	T4	N/A	T4	N/A	T135°C	N/A
E3	T6	T4	T6	T4	T85°C	T135°C
E4	T6	T4	T6	T4	T85°C	T135°C

Temperature code ratings for Zones are dependent on external process temperature factors and equipment enclosure configuration. See the above for specific temperature code ratings.

Ordering the TM500 Insertion

Instructions: To order a TM500 Insertion, please fill in each number block by selecting the codes from the corresponding features below.

Notes: The "Parent" model number and one of each "Feature" must be specified. Example: TM500-09I-E1-RS

PARENT	FEATURES			OPTIONS
	1	2	3	1
TM500	<input type="text"/>	<input type="text"/>	<input type="text"/>	<input type="text"/>

Parent	
TM500	Insertion Mass Flow Meter; includes two 4-20mA outputs, pulse output, contact input, display and configuration panel, USB connection, Gas-Mix (optional). TM-Cal Calibration Validation diagnostic for in-situ calibration in the field.

Feature 1: Probe	
06I	Insertion meter with 6-inch probe
09I	Insertion meter with 9-inch probe
12I	Insertion meter with 12-inch probe
15I	Insertion meter with 15-inch probe
18I	Insertion meter with 18-inch probe
24I	Insertion meter with 24-inch probe
30I	Insertion meter with 30-inch probe
36I	Insertion meter with 36-inch probe
15R	15" probe w/ 150-psi hot-tap & full port valve, 1" male NPT, 316 SS wetted parts
18R	18" probe w/ 150-psi hot-tap & full port valve, 1" male NPT, 316 SS wetted parts
24R	24" probe w/ 150-psi hot-tap & full port valve, 1" male NPT, 316 SS wetted parts
30R	30" probe w/ 150-psi hot-tap & full port valve, 1" male NPT, 316 SS wetted parts
36R	36" probe w/ 150-psi hot-tap & full port valve, 1" male NPT, 316 SS wetted parts

Feature 2: Enclosure	
E1	Local explosion-proof enclosure, 12-24 VDC powered
E2	Local explosion-proof enclosure, 100-240 VAC powered
E3	Remote explosion-proof J-box, 12-24 VDC powered, includes remote mounting kit, cable sold separately
E4	Remote explosion-proof J-box, 100-240 VAC powered, includes remote mounting kit, cable sold separately

Feature 3: Communication Options	
B0	No communications option
RS	RS485 Modbus RTU
BH	HART enabled on primary 4-20mA output

*Notes: See separate model code document for FlowTrak Flow Conditioners for use with insertion style flow meters.

Option 1: Gas-Mix	
GasMix	Gas-Mix Function - Choose from preset list of 14 gases (or mixtures of those gases) in the field as needed. NIST-traceable calibration. See list of gases on page 5.

Ordering the TM500 Inline

Instructions: To order a TM500 Inline, please fill in each number block by selecting the codes from the corresponding features below and following pages.

Notes: The "Parent" model number and one of each "Feature" must be specified. Example: TM500-40F-E1-RS

PARENT	FEATURES			OPTIONS
	1	2	3	1
TM500				

Parent	
TM500	Inline Mass Flow Meter; includes two 4-20mA outputs, pulse output, contact input, display and configuration panel, USB connection, Gas-Mix (optional). TM-Cal Calibration Validation diagnostic for in-situ calibration in the field.

Feature 1: 316 Stainless Steel Flow Body

075P	3/4 inch flow body (schedule 40), male NPT ends, 12" face-to-face length
10P	1 inch flow body (schedule 40), male NPT ends, 12" face-to-face length
125P	1-1/4 inch flow body (schedule 40), male NPT ends, 12" face-to-face length
15P	1-1/2 inch flow body (schedule 40), male NPT ends, 12" face-to-face length
20P	2 inch flow body (schedule 40), male NPT ends, 12" face-to-face length
25P	2-1/2 inch flow body (schedule 40), male NPT ends, 18" face-to-face length
30P	3 inch flow body (schedule 40), male NPT ends, 18" face-to-face length
075F	3/4 inch flow body (schedule 40), 150# RF flange ends, 12" face-to-face length
10F	1 inch flow body (schedule 40), 150# RF flange ends, 12" face-to-face length
125F	1-1/4 inch flow body (schedule 40), 150# RF flange ends, 12" face-to-face length
15F	1-1/2 inch flow body (schedule 40), 150# RF flange ends, 12" face-to-face length
20F	2 inch flow body (schedule 40), 150# RF flange ends, 12" face-to-face length
25F	2-1/2 inch flow body (schedule 40), 150# RF flange ends, 18" face-to-face length
30F	3 inch flow body (schedule 40), 150# RF flange ends, 18" face-to-face length
40F	4 inch flow body (schedule 40), 150# RF flange ends, 18" face-to-face length**
60F	6 inch flow body (schedule 40), 150# RF flange ends, 24" face-to-face length**
15G	1-1/2 inch flow body (schedule 40), 300# RF flange ends, 12" face-to-face length
20G	2 inch flow body (schedule 40), 300# RF flange ends, 12" face-to-face length
25G	2-1/2 inch flow body (schedule 40), 300# RF flange ends, 18" face-to-face length
30G	3 inch flow body (schedule 40), 300# RF flange ends, 18" face-to-face length
40G	4 inch flow body (schedule 40), 300# RF flange ends, 18" face-to-face length**
60G	6 inch flow body (schedule 40), 300# RF flange ends, 24" face-to-face length**

Note: If max. flow rate above 2,500 SCFM (4,250 NM3H), consult factory for application review.

Feature 2: Enclosure

E1	Local explosion-proof enclosure, 12-24 VDC powered
E2	Local explosion-proof enclosure, 100-240 VAC powered
E3	Remote explosion-proof J-box, 12-24 VDC powered, includes remote mounting kit, cable sold separately
E4	Remote explosion-proof J-box, 100-240 VAC powered, includes remote mounting kit, cable sold separately

Feature 3: Communication Options

B0	No communications option
RS	RS485 Modbus RTU
BH	HART enabled on primary 4-20mA output

Option 1: Gas-Mix

GasMix	Gas-Mix Function - Choose from preset list of 14 gases (or mixtures of those gases) in the field as needed. NIST-traceable calibration. See list of gases on page 5.
---------------	----------------------------------------------------------------------------------------------------------------------------------------------------------------------



Measurably Different™

Sierra Instruments

North America

20 Ryan Ranch Rd, Suite 109
Monterey, California 93940
+1.831.373.0200 • sierrainstruments.com

EMEA

Bijlmansweid 2
1934RE Egmond aan den Hoef • The Netherlands
+31 72 5071400

Asia

Second Floor Building 5 • Senpu Industrial Park • 25 Hangdu
Road Hangtoun Town • Pu Dong New District • Shanghai, P.R.
China 201316 • +8621 5879 8521/22