



InnovaSonic® 205i Modbus

Instruction Manual

Modbus Device Specification for
InnovaSonic® 205
Transit-Time Ultrasonic Flow Meter



Part Number: IM205i Modbus, Rev. V2

January 2015



SIERRA®
EXPERIENCE OUR PASSION FOR FLOW!

GLOBAL SUPPORT LOCATIONS: WE ARE HERE TO HELP!

CORPORATE HEADQUARTERS

5 Harris Court, Building L, Monterey, CA 93940

Phone (831) 373-0200 (800) 866-0200 Fax (831) 373-4402

www.sierrainstruments.com

EUROPE HEADQUARTERS

Bijlmansweid 2 1934RE Egmond aan den Hoef

The Netherlands

Phone +31 72 5071400 Fax +31 72 5071401

ASIA HEADQUARTERS

Second Floor Building 5, Senpu Industrial Park

25 Hangdu Road Hangtoun Town

Pu Dong New District, Shanghai, P.R. China

Postal Code 201316

Phone: + 8621 5879 8521 Fax: +8621 5879 8586

IMPORTANT CUSTOMER NOTICE- OXYGEN SERVICE

Sierra Instruments, Inc. is not liable for any damage or personal injury, whatsoever, resulting from the use of Sierra Instruments standard mass flow meters for oxygen gas. You are responsible for determining if this mass flow meter is appropriate for your oxygen application. You are responsible for cleaning the mass flow meter to the degree required for your oxygen flow application.

© COPYRIGHT SIERRA INSTRUMENTS 2014

No part of this publication may be copied or distributed, transmitted, transcribed, stored in a retrieval system, or translated into any human or computer language, in any form or by any means, electronic, mechanical, manual, or otherwise, or disclosed to third parties without the express written permission of Sierra Instruments. The information contained in this manual is subject to change without notice.

TRADEMARKS

InnovaSonic® is a trademark of Sierra Instruments, Inc. Other product and company names listed in this manual are trademarks or trade names of their respective manufacturers.

Warnings and Cautions



Warning! Agency approval for hazardous location installations varies between flowmeter models. Consult the flow meter nameplate for specific flow meter approvals before any hazardous location installation.

Warning! Hot tapping must be performed by a trained professional. U.S. regulations often require a hot tap permit. The manufacturer of the hot tap equipment and/or the contractor performing the hot tap is responsible for providing proof of such a permit.

Warning! All wiring procedures must be performed with the power off.

Warning! To avoid potential electric shock, follow National Electric Code safety practices or your local code when wiring this unit to a power source and to peripheral devices. Failure to do so could result in injury or death. All AC power connections must be in accordance with published CE directives.

Warning! Do not power the flow meter with the sensor remote (if applicable) wires disconnected. This could cause over-heating of the sensors and/or damage to the electronics.

Warning! Before attempting any flow meter repair, verify that the line is de-pressurized.

Warning! Always remove main power before disassembling any part of the mass flow meter.



Caution! Before making adjustments to the device, verify the flow meter is not actively monitoring or reporting to any master control system. Adjustments to the electronics will cause direct changes to flow control settings.

Caution! All flow meter connections, isolation valves and fittings for hot tapping must have the same or higher pressure rating as the main pipeline.

Caution! Changing the length of cables or interchanging sensors or sensor wiring will affect the accuracy of the flow meter. You cannot add or subtract wire length without returning the meter to the factory for re-calibration.

Caution! When using toxic or corrosive gases, purge the line with inert gas for a minimum of four hours at full gas flow before installing the meter.

Caution! The AC wire insulation temperature rating must meet or exceed 80°C (176°F).

Caution! Printed circuit boards are sensitive to electrostatic discharge. To avoid damaging the board, follow these precautions to minimize the risk of damage:

- before handling the assembly, discharge your body by touching a grounded, metal object
- handle all cards by their edges unless otherwise required
- when possible, use grounded electrostatic discharge wrist straps when handling sensitive components

Note and Safety Information

We use caution and warning statements throughout this book to draw your attention to important information.



Warning!

This statement appears with information that is important to protect people and equipment from damage. Pay very close attention to all warnings that apply to your application.



Caution!

This statement appears with information that is important for protecting your equipment and performance. Read and follow all cautions that apply to your application.

Receipt of System Components

When receiving a Sierra mass flow meter, carefully check the outside packing carton for damage incurred in shipment. If the carton is damaged, notify the local carrier and submit a report to the factory or distributor. Remove the packing slip and check that all ordered components are present. Make sure any spare parts or accessories are not discarded with the packing material. Do not return any equipment to the factory without first contacting Sierra Customer Service.

Technical Assistance

If you encounter a problem with your flow meter, review the configuration information for each step of the installation, operation, and setup procedures. Verify that your settings and adjustments are consistent with factory recommendations. Installation and troubleshooting information can be found in the [InnovaSonic 205i Product Instruction Manual](#).

If the problem persists after following the troubleshooting procedures outlined in the 640S or 780S product manuals, contact Sierra Instruments by fax or by E-mail (see inside front cover). For urgent phone support you may call (800) 866-0200 or (831) 373-0200 between 8:00 a.m. and 5:00 p.m. PST. In Europe, contact Sierra Instruments Europe at +31 20 6145810. In the Asia-Pacific region, contact Sierra Instruments Asia at +86-21-58798521. When contacting Technical Support, make sure to include this information:

- The flow range, serial number, and Sierra order number (all marked on the meter nameplate)
- The software version (visible at start up)
- The problem you are encountering and any corrective action taken
- Application information (gas, pressure, temperature and piping configuration)

Table of Contents

Chapter 1: Using Modbus with the InnovaSonic 205i	6
1.1. RS-232 / RS-485 Pin Definitions	6
1.2. Connection of RS-232 or RS-485.....	7
1.3. Setting Up the 205i to Use Modbus RTU	7
1.4. Modbus-RTU Protocol.....	8

Chapter 1: Using Modbus with the InnovaSonic 205i

Overview

The flow meter comes standard with a RS-485 multi-drop and RS-232 point to point connection. RS-232 can be used for point to point (one master one slave 205i) communication with wire runs of 50 feet or less. The RS-485 can be used to communicate over 1,000 meters, baud rate dependent with several 205i slaves on one wire pair. This could be up to 30, 205is on one RS-485 segment, and 127 on a whole RS-485 network.

Both RS-485 and RS-232 communication can be used with the Modbus RTU protocol. The network address identifying code (IDN) is set in Menu 46. Although RS-232 doesn't normally use an address, when using the Modbus protocol it does.

When using digital commutations the analog current loop and OCT output of flow meter can be free to be used to control the opening of a control valve. The relay output can be used to power-on/off other equipment. The analog input of the system can be used to input signals such as pressure and temperature. These analog values can be read using the Modbus RTU protocol to be used by customer software..

RS-232(<50 ft.) or RS-485 (up to 4,000 ft.) can be directly used for data transmission link for a short distance. Current loop, radio transmission and modems can be used in medium or very long distance transmission.

When the flow meter is used in a network environment, various operations can be performed at the host device, except for programming of the address identification code, which needs to be done at the flow meter keyboard. The command answer mode is used in data transmission, i.e. the host device issues commands and the flow meter answers correspondingly.



ATTENTION

RS-232 and RS-485 serial communications cannot be used at the same time.

1.1. RS-232 / RS-485 Pin Definitions

Flow Meter:	PC COM Port:
TXD receive	Pin 2 Rx
RXD send	Pin 3 Tx
GND	Pin 5 GND

Flow Meter:	RS-485	2	Wire
Network:			
A	A (-)		
B	B (+)		
GND	GND		

Note: A&B may need to be reversed

1.2. Connection of RS-232 or RS-485

See the above list of flow meter serial port definitions.

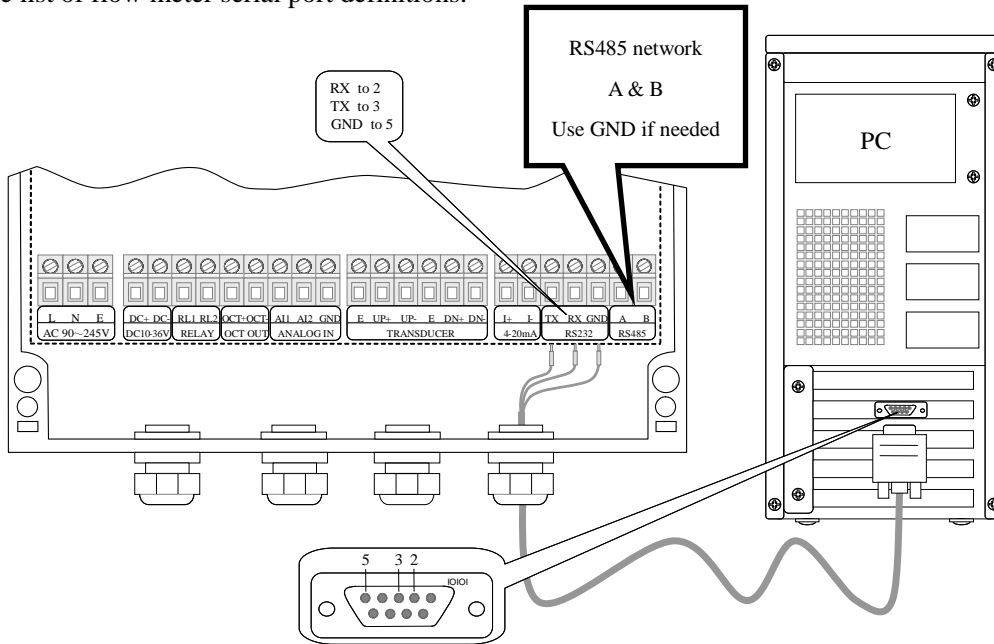

1.3 Setting Up the 205i to Use Modbus RTU

Menu **4** **6**

Press Enter, when the > cursor appears type in your entry. Press enter when done.

Input the Modbus address your 205i will be using on your network. These numbers can be selected from 0-65535; however Modbus only supports 1-255. The 205i has some reserved addresses you can't use; 13 (0DH ENTER), 10 (0AH Newline), 42 (2AH), and 38 (26H).

```
Network IDN [46
              88
```

Menu **6** **2**

Press Enter, when the > cursor appears use the **↑** and **↓** keys to make your selection. Press **Enter** when done.

This window is used to setup the Modbus serial port baud rates. Your choices are 9600, 19200, 38400, 56000, 57600, or 115200. This setting must match the master and other slaves on your Modbus network. The Parity is fixed at None, Data length fixed to eight, Stop bit fixed at 1.

Default factory serial port parameters are: "9600, 8, None, 1".

```
RS-232 Setup [62
              9600, None
```

1.4 Modbus-RTU Protocol

The flow meter protocol supports the following two-function codes of the Modbus:

Function Code	Performance Data
0x03	Read register
0x06	Write single register

1) Modbus Protocol function code 0x03 usage.

The host sends out the read register information frame format:

Slave Address	Operation Function Code	First Address Register	Register Number	Verify Code
1 byte	1 byte	2 bytes	2 bytes	2 bytes
0x01~0xF7	0x03	0x0000~0xFFFF	0x0000~0x7D	CRC(Verify)

The slave returns the data frame format:

Slave Address	Read Operation Function Code	Number of Data Bytes	Data Bytes	Verify Code
1 byte	1 byte	1 byte	N*x2 byte	2 byte
0x01~0xF7	0x03	2xN*	N*x2	CRC(Verify)

N*=data register number

2) Modbus Protocol function code 0x06 usage.

The host sends a command to write a single register information frame format (performance code 0x06):

Slave Address	Operation Function Code	Register Address	Register Data	Verify Code
1 byte	1 byte	2 bytes	2 bytes	2 bytes
0x01~0xF7	0x06	0x0000~0xFFFF	0x0000~0xFFFF	CRC(Verify)

The slave returns the data frame format (performance code 0x06):

Slave Address	Operation Function Code	Register Address	Register Data	Verify Code
1 byte	1 byte	2 bytes	2 bytes	2 bytes

0x01~0xF7	0x06	0x0000~0xFFFF	0x0000~0xFFFF	CRC(Verify)
-----------	------	---------------	---------------	-------------

The range of flow meter addresses are 1-247, and can be checked in the Menu 46. For example, decimal number “11” displayed on Menu 46 means the address of the flow meter in the Modbus protocol is 0x0B.

The CRC Verify Code adopts CRC-16-IBM (polynomial is $X^{16}+X^{15}+X^2+1$, shield character is 0xA001) which is gained by the cyclic redundancy algorithm method. Low byte of the verify code is at the beginning while the high byte is at the end.

For example, to read the address 1 (0x01) in the RTU mode, if the instantaneous flow rate uses hour as a unit (m³/h) , namely reads 40005 and 40006 registers data, the read command is as follows:

0x01 0x03 0x00 0x04 0x00 0x02 0x85 0xCA

Flow Meter Address Function Code First Address Register Register Numbers CRC Verify Code

Flow Meter returned data is (assuming the current flow=1.234567m³/h)

0x01 0x03 0x04 0x06 0x51 0x3F 0x9E0x3B 0x32

Flowmeter Address Function Code Data Bytes Data (1.2345678) CRC Verify Code

The four bytes 3F 9E 06 51 is in the IEEE754 format single precision floating point form of 1.2345678.

Pay attention to the data storage order of the above example. Using C language to explain the data, pointers can be used directly to input the required data in the corresponding variable address, the low byte will be put at the beginning, such as the above example 1.2345678 m/s, 3F 9E 06 51 data stored in order as 51 06 9E 3F.

For example, it converts the address 1 (0x01) to 2 (0x02) under the RTU mode, so to write the data of flowmeter 44100 register as 0x02, the write command is as follows:

0x01 0x06 0x10 0x03 0x00 0x02 0xFC 0xCB

Flowmeter Address Function Code Register Address Register Number CRC Verify Code

Flowmeter returned data is:

0x01 0x06 0x10 0x03 0x00 0x02 0xFC 0xCB

Flowmeter Address Function Code Register Address Register Number CRC Verify Code

3) Error Check

The flow meter only returns one error code 0x02 which means data first address in error.

For example, to read address 1 (0x01) of the flow meter 40002 register data in the RTU mode, the flow meter considers it to be invalid data, and sends the following command:

0x01 0x03 0x00 0x01 0x00 0x01 0xD5 0xCA

Flowmeter Address Function Code Register Address Register Number CRC Verify Code

Flowmeter returned error code is:

0x01 0x83 0x02 0xC0 0xF1

Flowmeter Address Error Code Error Extended Code CRC Verify Code

4) Modbus Register Address List

Most commercially available Modbus host software uses a register format. See Modbus.org for more details. This format is much easier to use. By using the 40000 registers, function code 0x 03 is automatically used for reads and function code 0x 06 is automatically used for single register writes. The CRC checksum is also automatically calculated and added to the data frame, as well as verified on the returned data frame. Error codes are received and decoded.

Modbus host software also allows for easy decoding of the data. The 205i uses the following data types:

32 bits real: Float or IEE754 (LSB-MSB byte order)

32 bits int.: 32 bit un-signed integer. Allows for a number from 0 to 4,294,967,295 (LSB-MSB byte order)

16 bits int: 16 bit signed integer. This allow for a number between -65,535 and +65,534

String: 8 bit ASCII characters, 2 per 16 bit register.

PDU Address	Register	Read	Write	Type	No. Registers*
\$0000	40001	Flow/s - low word	32 bits real	2	
\$0001	40002	Flow/s - high word			
\$0002	40003	Flow/m - low word	32 bits real	2	
\$0003	40004	Flow/m- high word			
\$0004	40005	Flow/h - low word	32 bits real	2	
\$0005	40006	Flow/h - high word			
\$0006	40007	Velocity – low word	32 bits real	2	
\$0007	40008	Velocity – high word			
\$0008	40009	Positive total – low word	32 bits int.	2	
\$0009	40010	Positive total – high word			
\$000A	40011	Positive total – exponent	16 bits int.	1	
\$000B	40012	Negative total – low word	32 bits int.	2	
\$000C	40013	Negative total – high word			
\$000D	40014	Negative total – exponent	16 bits int.	1	
\$000E	40015	Net total – low word	32 bits int.	2	
\$000F	40016	Net total – high word			
\$0010	40017	Net total – exponent	16 bits int.	1	
\$0011	40018	Energy total – low word	32 bits int.	2	

\$0012	40019	Energy total – high word			
\$0013	40020	Energy total – exponent	16 bits int.	1	
\$0014	40021	Energy flow – low word	32 bits real	2	
\$0015	40022	Energy flow – high word			
\$0016	40023	Up signal int – low word	32 bits real	2	0~99.9
\$0017	40024	Up signal int – high word			
\$0018	40025	Down signal int – low word	32 bits real	2	0~99.9
\$0019	40026	Down signal int – high word			
\$001A	40027	Quality	16 bits int.	1	0~99
\$001B	40028	Analog output – low word	32 bits real	2	Unit: mA
\$001C	40029	Analog output – high word			
\$001D	40030	Error code – char 1,2	String	3	Refer to “Error Analysis” for detailed codes meanings.
\$001E	40031	Error code – char 3,4			
\$001F	40032	Error code – char 5,6			
\$003B	40060	Velocity unit – char 1,2	String	2	Currently supports m/s only
\$003C	40061	Velocity unit – char 3,4			
\$003D	40062	Flow unit – char 1,2	String	2	Note 1
\$003E	40063	Flow unit – char 3,4			
\$003F	40064	Total unit – char 1,2	String	1	
\$0040	40065	Reserved			
\$0041	40066	Reserved			
\$0042	40067	Reserved			
\$0043	40068	ID code – low word	32 bits int.	2	
\$0044	40069	ID code – high word			
\$0045	40070	Serial number – char 1,2	String	4	
\$0046	40071	Serial number – char 3,4			
\$0047	40072	Serial number – char 5,6			

\$0048	40073	Serial number – char 7,8			
\$0049	40074	Reserved			
\$004a	40075	Reserved			
\$004b	40076	Reserved			
\$004c	40077	Reserved			

a) Single Write Register Address List (use 0x06 performance code to write)

PDU Address	Register	Description	Read/Write	Type	No. Registers*
\$1003	44100	Flowmeter address (1-247)	R/W	16 bits int.	1
\$1004	44101	Communication Baud Rate 1 = 4800, 2 = 9600 3 = 19K2, 4 = 38K4 ,5 = 57K6	R/W	16 bits int.	1

Notes:

1. The following flow rate units are available:

0. “m3” —Cubic Meter
1. “l” —Liters
2. “ga” —Gallons
3. “ig” —Imperial Gallons
4. “mg” —Million Gallons
5. “cf” —Cubic Feet
6. “ba” —US Barrels
7. “ib” —Imperial Barrels

“ob” —Oil Barrels