

RedySmart® Series

MEMS Thermal Mass Flow Meters & Controllers

RedySmart® Mass Flow Meters (GSM)
RedSmart® Mass Flow Controllers (GSC)
RedySmart® Pressure Controllers (GSP)
RedySmart® Back Pressure Controllers (GSB)

Instruction Manual



Part Number: IM-RedySmart
V5.smart_E6_7



Global Support Locations: We are here to help!

CORPORATE HEADQUARTERS

5 Harris Court, Building L Monterey, CA 93940
Phone (831) 373-0200 (800) 866-0200 Fax (831) 373-4402
info@sierrainstruments.com
www.sierrainstruments.com

EUROPE HEADQUARTERS

Bijlmansweid 2 1934RE Egmond aan den Hoef
The Netherlands
Phone +31 72 5071400 Fax +31 72 5071401
sales@sierrainstruments.nl

ASIA HEADQUARTERS

Second Floor Building 5, Senpu Industrial Park
25 Hangdu Road Hangtou Town
Pu Dong New District, Shanghai, P.R. China
Postal Code 201316
Phone: + 8621 5879 8521 Fax: +8621 5879 8586
orders@sierra-asia.com

For Global Service Centers, go to <http://www.sierrainstruments.com/facilities.html>

Important Customer Notice- Oxygen Service

Sierra Instruments, Inc. is not liable for any damage or personal injury, whatsoever, resulting from the use of Sierra Instruments standard mass flow meters for oxygen gas. You are responsible for determining if this mass flow meter is appropriate for your oxygen application. You are responsible for cleaning the mass flow meter to the degree required for your oxygen flow application.

© Copyright 2023 and Liability Disclaimer

All rights reserved. No part of this publication may be copied or distributed, transmitted, transcribed, stored in a retrieval system, or translated into any human or computer language, in any form or by any means, electronic, mechanical, manual, or otherwise, or disclosed to third parties without the express written permission of Sierra Instruments.



The content of this manual is provided for information only and may be altered without prior notice. Sierra Instruments assumes no responsibility or liability for any errors or inaccuracies in this manual. For the latest information on our products, visit our website www.sierrainstruments.com

TRADEMARKS

RedySmart® and Redy® are registered trademark of Sierra Instruments. Other product and company names listed in this manual are trademarks or trade names of their respective manufacturers.

Warnings and Cautions

“Warning,” “Caution,” and “Note” statements are used throughout this manual to draw your attention to important information.

Symbol Key		
Symbol	Symbol Meaning	Description
	Warning	“Warning” statements appear with information that is important to protect people and equipment from damage. Pay very close attention to all warnings that apply to your application. Failure to comply with these instructions may damage the meter and cause personal injury.
	Caution	“Caution” indicates that failure to comply with stated instructions may result in damage or faulty operation of the meter.
	Note	“Note” indicates that ignoring the relevant requirements or precautions may result in flow meter damage or malfunction.



Warning! Do not remove the black cover- it prevents damage to the system. A damaged hologram seal will expire (cancel) the warranty.

Warning! Removing the cover voids the warranty.

Warning! There are no serviceable parts under the cover.

Warning! Repairs must be performed by a qualified Sierra personnel.

Warning! Connect the device to a protective ground conductor (earth).

Warning! The device must be grounded. The supply voltage is 18-30 VDC (typically ± 50 mV).

Warning! Due to our policy of ongoing product development, we reserve the right to change the information in this manual without notice.

Warning! Regarding TOXIC, Flammable Gases and ATEX: In the case of toxic and flammable gases, the respective safety guidelines in each country must be followed. The RedySmart devices are not approved for use in Ex- zones. In the case of flammable and toxic gases, fittings and pipes intended for that purpose must be used. The responsibility for safe operation lies with the designer of the facilities. The devices must not be used for explosive mixtures. (ATEX, detonating gas, consisting of O₂ and H₂).

Warning! Agency approval for hazardous location installations varies between flow meter models. Consult the flow meter nameplate for specific flow meter approvals before any hazardous location installation.

Warning! All wiring procedures must be performed with the power off.

Warning! To avoid potential electric shock, follow National Electric Code safety practices or your local code when wiring this unit to a power source and to peripheral devices. Failure to do so could result in injury or death. All AC power connections must be in accordance with published CE directives.

Warning! Do not power the flow meter with the sensor remote (if applicable) wires disconnected. This could cause over-heating of the sensors and/or damage to the electronics.

Warning! Before attempting any flow meter repair, verify that the line is de-pressurized.

Warning! Always remove main power before disassembling any part of the mass flow meter.

RedySmart® Series Instruction Manual

Part 1: General Operating Instructions

This manual is for RedySmart Series models:

- RedySmart Meter (GSM)
- RedySmart Controller (GSC)
- RedySmart Pressure Controller (GSP)
- RedySmart Back Pressure Controller (GSB)

This manual is valid for instruments with a serial number starting from 110 000.

Receipt of System Components

When receiving a Sierra mass flow meter, carefully check the outside packing carton for damage incurred in shipment. If the carton is damaged, notify the local carrier and submit a report to the factory or distributor. Remove the packing slip and check that all ordered components are present. Make sure any spare parts or accessories are not discarded with the packing material. Do not return any equipment to the factory without first contacting Sierra Customer Service.

Technical Assistance

If you encounter a problem with your flow meter, review the configuration information for each step of the installation, operation, and setup procedures. Verify that your settings and adjustments are consistent with factory recommendations. Installation and troubleshooting information can be found in this manual. See Chapter 1 and 3 for installation and Chapter 7 for troubleshooting.

If the problem persists after following the troubleshooting procedures outlined in the RedySmart product manual, contact Sierra Instruments by fax or by E-mail (see inside front cover). For urgent phone support you may call (800) 866-0200 or (831) 373-0200 between 8:00 a.m. and 5:00 p.m. PST. In Europe, contact Sierra Instruments Europe at +31 20 6145810. In the Asia-Pacific region, contact Sierra Instruments Asia at +86-21-58798521. When contacting Technical Support, make sure to include this information:

- The flow range, serial number, and Sierra order number (all marked on the meter nameplate)
- The software version (visible at start up)
- The problem you are encountering, and any corrective action taken
- Application information (gas, pressure, temperature and piping configuration)

Recycling



Note the existing regulations of your country.

Register Your Product Today

Three (3) Year Warranty (Sierra MEMS Thermal Mass Flow Sensor: RedySmart and RedyCompact Brands)

All Sierra products are warranted to be free from defects in material and workmanship and will be repaired or replaced at no charge to Buyer, provided return or rejection of product is made within a reasonable period but no longer than three (3) years for calibration and non-calibration defects, from date of delivery.

To assure warranty service, customers must register their products online on Sierra's website. Online registration of all of your Sierra products is required for our warranty process. Read complete warranty policy at www.sierrainstruments.com/warranty.

Lifetime NO-DRIFT Sensor Warranty (Sierra MEMS Thermal Mass Flow Sensor: RedySmart & RedyCompact brands)

In addition to Sierra's standard three (3) year manufacturing warranty on all MEMS mass flow instruments produced, Sierra also offers a Lifetime No-Drift Sensor Warranty. Sierra defines no-drift as less than 1% of full scale over the life of the instrument. Therefore, if drift of greater than 1% of full scale occurs over the sensor's lifetime, the sensor and/or entire instrument will be repaired or replaced and recalibrated free of charge.

This warranty applies to all MEMS/CMOS thermal mass flow sensors standard on every Sierra RedySmart™ and RedyCompact™ models sold after January 15, 2020. This warranty is only valid if the unit is exclusively used with the gas or gases specified during the initial calibration or recalibration, without any additives in any form and under the operating conditions (temperature, inlet and outlet pressure, full scale flow rate) the unit was originally specified for.

Sierra's Lifetime No-Drift Sensor Warranty is made possible due to high-precision MEMS (Micro-Electro Mechanical Systems) technology utilizing an advanced ultra-stable CMOS (Complementary Metal Oxide Semiconductor) sensor. The use of MEMS techniques allows both electronic circuits and mechanical devices to be manufactured on a silicon chip, similar to the process used for integrated circuits.

Learn more about Sierra's Lifetime No-Drift Sensor Warranty at www.sierrainstruments.com/warranty and in Appendix 8.

Table of Contents

Register Your Product Today	6
Table of Contents	7
1. Introduction	10
1.10 Features of Thermal Mass Flow Meters and Controllers	10
1.11 Scope of Warranty	10
1.12 Instructions and Warnings	11
1.13 Documentation -What We Supply	12
1.14 The Measurement Principle	12
1.15 CMOS Technology	13
1.16 Block Diagram	13
2. Technical Data	14
2.10 General Device Specifications	14
2.11 Mechanical Specifications	14
2.12 Electrical Data	15
2.13 Measurement Ranges (Air)	15
2.14 Plug Pin Assignment (Modbus, Power Supply, Analog Signals)	16
2.15 Analog Signals	16
2.16 Serial Interface	16
2.17 Plug Pin Assignment, PROFIBUS	17
2.18 Calibration	17
2.19 Operation with Other Gases	17
2.20 Pressure Loss	17
2.21 Temperature Compensation	18
2.22 Pressure Compensation	18
2.22 Response Time	18
2.23 Control Behavior	18
3. Installation and Commissioning	19
3.10 Mounting Position and Mounting Location	19
3.11 Requirements for Pipework	19
3.12 Sealants	20
3.13 Recommended Filter Fittings:	20
3.14 Filters / Gas Cleanliness	20
3.15 Electrical Power Supply	21
3.16 Grounding	22
3.17 Led Operating Status Display	23
3.18 Display	24
4. Operation and Maintenance	27
4.10 Warm-Up Time	27

4.11	Maintenance / Calibration Check	27
4.12	Cleaning to Remove Contamination	27
4.13	Return	28
5.	RedySmart Smart Interface Portal Software (SIP)	29
5.10	Introduction	29
5.11	Installation	29
5.12	Functions	29
5.13	On-Screen Help	29
5.14	Digital Communication	30
6.	Pressure Control	31
6.10	Characteristics	31
6.11	Description of The Application	31
6.12	Requirements	31
6.13	Pressure Control (Pressure Controller, GSP)	32
6.14	Back Pressure Control (Back Pressure Controller, GSB)	32
6.15	Technical Data	33
6.16	Block Diagram	33
6.17		33
6.17	Electrical Power Supply	34
6.18	Connection Diagram	34
6.19	Settings for Control Parameters	34
6.20	Configuration With the RedySmart Smart Interface Portal Software	35
6.21	Pressure Conversion Table	36
7.	Appendix	37
7.10	Troubleshooting	37
7.11	Measurement & Control of Flow Rate	37
7.12	Pressure Control	41
7.13	Pressure Loss	43
7.14	Dimensional Drawings	45
	GSM, Types A, B, C	45
	GSC, Types A, B, C	46
	GSM, GSC, Type D	47
	GSC, Type D, With Valve Type 8.0 (Double Valve)	48
	GSP	49
7.15	Accessories	50
7.16	Communication Cable PDM-U	50
7.17	Type Code GSM / GSC	51
7.18	Type Code Pressure Controller GSB / GSP	53
7.19	Wetted Parts RedySmart Series SN > 110 000	55
7.20	Change History	56

8. Appendix B- Detailed Warranty Statement for RedySmart & RedyCompact Brands

57

1. Introduction

Thank you for choosing devices from the RedySmart™ Series. These operating instructions will help you to install and operate the measuring devices. Please read through these instructions carefully before installing the devices. Our aim has been to write a full and practical guide. We would be grateful if you would notify us of any shortcomings or mistakes.

Please contact [Sierra Instruments" Customer Service](#) if you have questions about any aspect of the product (s), you may call (800) 866-0200 or (831) 373-0200 between 8:00 a.m. and 5:00 p.m. PST. In Europe, contact Sierra Instruments Europe at +31 20 6145810. In the Asia-Pacific region, contact Sierra Instruments Asia at +86-21-58798521.

The core element of the RedySmart thermal mass flow meter and controller is a CMOS sensor chip. The sensor and parts of the electronics are on one board and offer a number of advantages for the user.

1.10 Features of Thermal Mass Flow Meters and Controllers

In developing and manufacturing the devices, we have focused primarily on customers and their applications. Our aim is to implement customers" requirements in the form of new developments or enhancements on an ongoing basis. The essential features are:

- Compact design
- Standardized digital and analog interfaces
- Very fast and accurate measurement and control
- Integrated temperature measurement and totalizer (standard)
- Easy to maintain and service
- Thanks to its modular design, the unit can be easily expanded to add additional functions
- 3-year warranty
- Matched options and accessories

1.11 Scope of Warranty

Warranty for the RedySmart product line extends to material and manufacturing defects only. Maximum warranty covers product replacement free of charge. The following causes of faults/damage are not covered under warranty:

- Use outside the operating limits
- Damage due to corrosion
- Mechanical damage in general
- Contamination due to improper sealing
- Contamination due to impure gasses or penetration of liquids
- Damage to electronic components due by over-voltage or electrostatic discharges, and corrosion damage due to aggressive environments.
- Functional failure due to incorrect operation or faulty parameterization

- Drift in the calibration

1.12 Instructions and Warnings

Read all of the operating instructions thoroughly before installing and commissioning equipment. Misconceptions and incorrect use can lead to breakage of the measuring device or risk of personal injury.

The installation, commissioning and operation and maintenance must be done by appropriately qualified personnel.

1.12.1 Installation

	<p>Important Note</p> <p>Please note before the start-up:</p> <ul style="list-style-type: none">• Do not use sealing tape or liquid sealant• Piping must be cleaned before installation of instrument
---	---

Products in this manual may contain metal or elastomeric seals, gaskets, O-rings or valve seats. It is the user's responsibility to select materials that are compatible with their process and process conditions.

	<p>Important Note</p> <p>Using materials that are not compatible with the process or process conditions could result in the devices leaking gas outside the pressure boundary of the device, resulting in personnel injury or death.</p>
---	---

It is recommended that the user check the devices on a regular schedule to ensure that it is leak free as both metal and elastomeric seals, gaskets, O-rings and valve seats may change with age, exposure to process gas.

1.12.2 Power

If it becomes necessary to remove the instrument from the system, power to the device must be disconnected.

1.12.3 Troubleshooting

OEM tool problems are often caused by various errors. Therefore, Sierra recommends that you review both the manual of the OEM tool and troubleshooting guide, in Chapter 7, before removing the instrument from your system.

1.13 Documentation -What We Supply

Each product shipment includes the following accompanying documentation:

- One factory calibration certificate (with each device)
- One final inspection report (with each device)
- Product Information Card with software download information
- Quick Start Guide
- Further information available for download on our website
 - All data sheets
 - Contamination clarification
 - Various certificates and declarations
 - General Terms and Conditions of Sale

1.14 The Measurement Principle

The thermal measurement principle is particularly suitable for the flow measurement and control of gaseous media. The most significant advantage is that the measurement process is largely independent of temperature and pressure. The displayed flow refers to the expanded gas volume at 0°C and 1013.25 mbar absolute. On request, other reference temperatures can be provided for. Most gas suppliers in Europe base their volume data on 15 °C and 1013.25 mbar absolute. According to the ideal gas law, the gas volume will change by 0.35% per K.

Stated simply, the thermal measurement principle measures the heat transport by gas flowing past.

In the case of *RedySmart* mass flow measuring instruments, a constant heat input gives a flow-dependent temperature difference (ΔT). Two temperature sensors are positioned in the measuring channel (T1, T2), one before the heating system (H) and one after it.

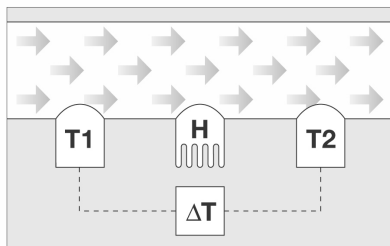

Figure 1: The measurement principle

If there is no flow, the heat spreads symmetrically in directions T1 and T2. The temperature difference T1-T2 is therefore zero.

Flow rates > 0 create a temperature difference.

The sensor T1 at the inlet is cooled by the gas flowing past it, and the temperature of the second sensor T2 rises due to the heat drawn from the heating system.

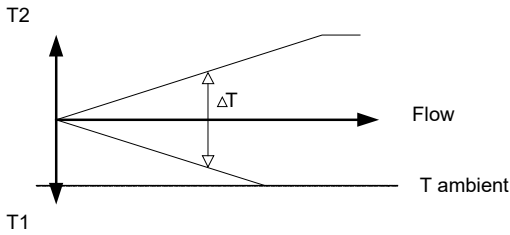

Figure 2: Sensor signals

The temperature difference is directly proportional to the mass flow.

1.15 CMOS Technology

The RedySmart measuring and control devices are equipped with an innovative semiconductor sensor that sets new standards for accuracy, speed and measurement dynamics. Thanks to the compact single-chip design, CMOS-based sensors are highly resistant to electromagnetic interference (EMC).

With CMOS technology (which we use), the sensor element, amplifier and A/D converter form a single unit on the silicon chip.

1.16 Block Diagram

The following block diagram shows the structure of the device.

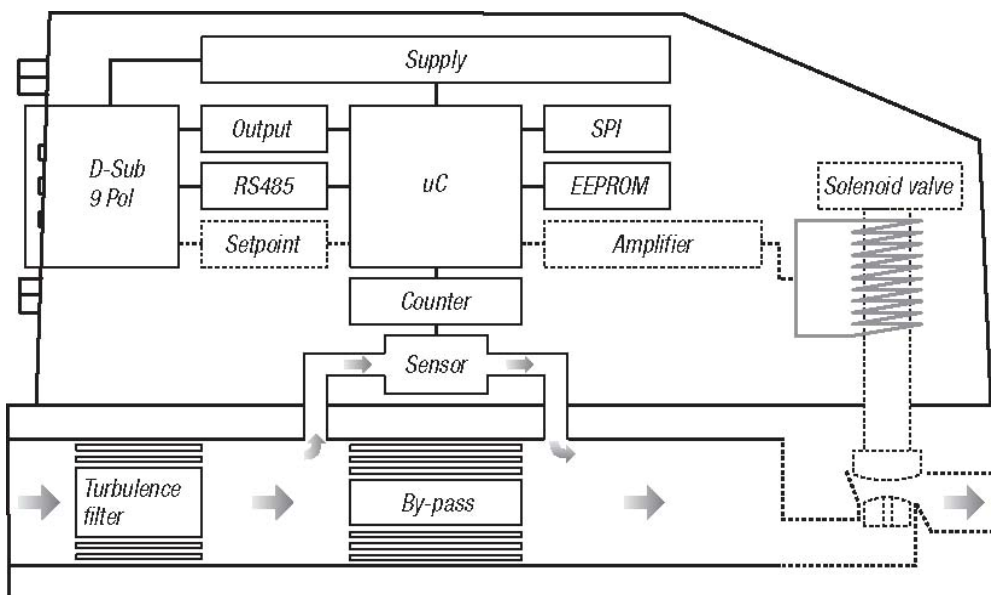

Figure 3: Block diagram

2. Technical Data

2.10 General Device Specifications

Accuracy	
Standard	±1.0% of full scale
Hi-Performance GSM < 200 In/min Air GSC < 150 In/min Air	±0.3% of full scale, ±0.5% of reading
Dynamics	
Standard	1:50 (signal suppression less than 0.85% of full scale)
Hi-Performance	1:100 (signal suppression less than 0.8% of full scale)
Response time:	50 ms
Reproducibility:	±0,2% of full scale
Long-term stability:	< 1% of reading / year
Temperature coefficient:	< 0.025% FS measuring range type / °C
Pressure coefficient:	< 0.2% / bar of reading (typical N2)
Control stability:	±0,2% of full scale
Working pressure range:	0.2 - 11 bar a (GSC with valve type 4.5 and 8 max 8bar s)
Test pressure:	16 bar a
Storage conditions:	-20 to 80°C (-4 to 176 F), 0-95% RH, non-considering
Temperature range:	0 – 50 °C (32 bis 122 F), 0-95%, RH, non-considering
	<i>Do not expose device to direct sun light.</i>
Leakage Rate	
Externally:	1 x 10 ⁻⁶ mbar*l/s He
Control valve:	1 x 10 ⁻⁶ mbar*l/s He
Warm-up time:	< 1 sec. for full accuracy
CE	CE Certified

2.11 Mechanical Specifications

Materials	
Code A model (aluminum):	Anodized aluminum, stainless steel 1.4305
Code S model (stainless steel):	Stainless steel 1.4305
Sensor area:	Silicon, glass, epoxy
Seal material:	FKM, optional EPDM or FFKM
Mechanical connection (types A, B, C):	G1/4-inch female thread at both ends, optional with fittings (see appendix "Accessories")
Mechanical connection (type D):	G1/2-inch female thread at both ends, optional with fittings (see appendix "Accessories")
Electrical power supply:	9-pin D-Sub plug connector (male)

(connections for supply, analog setpoint-actual values and Modbus RTU digital communication)

Protection class: IP-50
Wetted parts See appendix

2.12 Electrical Data

Supply voltage: 18-30 VDC (typically ± 50 mV)

Current Consumption

Flow meter, GSM: Max. 100 mA
Flow controller, GSC: Max. 250 mA (8 mm valve: max. 300 mA)

Analog Inputs and Outputs

Voltage: 0-5 V, 1-5 V, 1-10 V, 2-10 V, user-specific
Input impedance: 100 kohm
Minimum load: 1 kohm (at 24 VDC)
Current: 2-10 mA, 4-20mA, user-specific
Input impedance: 250 ohm
Maximum load: 900 ohm (at 24 VDC)

Digital Communication



RS-485, protocol: Modbus RTU (slave)
optional Profibus DP-V0, DP-V1

Control parameters: can be set via digital communication

2.13 Measurement Ranges (Air)

	Type	Measurement ranges (air), scale freely selectable	
smart meter GSM:	GSM-A	from 0 ... 25 nml/min	to 0 ... 0.6 nl/min
	GSM-B	from 0 ... 0.6 nl/min	to 0 ... 6 nl/min
	GSM-C	from 0 ... 6.0 nl/min	to 0 ... 60 nl/min
	GSM-D	from 0 ... 60 nl/min	to 0 ... 450 nl/min
smart controller GSC:	GSC-A	from 0 ... 25 nml/min	to 0 ... 0.6 nl/min
	GSC-B	from 0 ... 0.6 nl/min	to 0 ... 6 nl/min
	GSC-C	from 0 ... 6.0 nl/min	to 0 ... 60 nl/min
	GSC-D	from 0 ... 60 nl/min	to 0 ... 450 nl/min

2.14 Plug Pin Assignment (Modbus, Power Supply, Analog Signals)

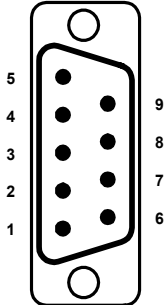

1	Common (-)	GND analog signals
2	Supply 0 VDC	0 VDC supply voltage
3	Supply +24 VDC	+24 VDC supply voltage
4	Output (+)	Analog output, measured value
5	Setpoint (+)	Analog input, setpoint
6	Tx+ RS-485	RS-485 Output (Y)
7	Tx- RS-485	RS-485 Output (Z)
8	Rx- RS-485	RS-485 Input (B)
9	Rx+ RS-485	RS-485 Input (A)

2.15 Analog Signals

The analog input and output signals can be configured with the RedySmart Smart Interface Portal Software which can be [downloaded](#) for free on our website.

The analog signals have no potential separation. Pin 1 and Pin 2 are connected internally. Potential differences have to be compensated with a suitable installation with external connections.

	<p>Important Note</p> <p>Please note that suitable isolating transformers have to be used for potential differences between the analog and digital range on the system side.</p>
--	---

2.16 Serial Interface

In addition to its analog interface, the RedySmart has, as standard, a digital interface with the Modbus protocol. This interface enables access to numerous parameters. In Part II of the operating instructions, [“Digital Communication” Instruction Manual](#), you will find all the information about the correct bus connection and the software parameters.

The digital interface has no potential separation.

	<p>Important Note</p> <p>Please note that suitable isolating transformers have to be used for potential differences between the digital communication and supply voltage on the system side.</p>
--	---

2.17 Plug Pin Assignment, PROFIBUS

An optional Profibus-DP interface is available. The pin assignment for the 9-pin Sub-D plug connection is shown in the following table.

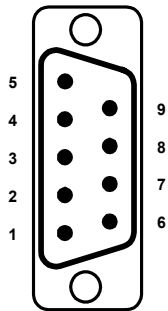

1	NC	-
2	NC	-
3	RxD/TxD-P	Data transmit / receive; data wire B
4	CNTR-P	Repeater control signal (RTS) (transmission-direction control)
5	DGND	Ground for data signals and VP
6	VP / +5V	Power supply +5 V
7	NC	-
8	RxD/TxD-N	Data transmit / receive; data wire A
9	NC	-

This website has further information about Profibus hardware:

<http://www.profibus.com/>

2.18 Calibration

Each measuring device is supplied with a factory calibration report. On request we can also provide DKD calibration (German Accreditation Body). The calibration is compatible with American and European standards. Each measuring device can store data for up to 10 types of gas or operational states.

2.19 Operation with Other Gases

	<p>Important Note</p> <p>Please note that, among other effects, the zero-point error (offset display) will be higher if the device is not operated with the type of gas, for which it had been calibrated.</p>
---	---

2.20 Pressure Loss

The thermal mass flow meters and controllers have a low pressure drop. This depends mainly on the medium, the pressure conditions and the flow rate. Your sales partner has a calculation program. You will find the pressure-loss curves for the measuring devices at the end of this guide. In the case of a flow controller, the pressure loss of the valve itself must be taken into account. Please note that the size of the pipes has a large effect on the pressure loss. From around 60 l/min, we recommend a pipe inside diameter of at least 10 mm.

2.21 Temperature Compensation

Thermal mass flow meters measure the flow of gases, the result being largely independent of pressure and temperature. The sensor measures the gas temperature and, with the help of a 3-dimensional table of interpolation values, a correction factor is calculated automatically. The available output signal is thus temperature-compensated. The accuracy of the temperature measurement is $\pm 1\text{ C}^\circ$ (33.8°F).

2.22 Pressure Compensation

During calibration, the specified operating pressure is allowed for. Changes to the pressure conditions may introduce an additional error. This is around $\pm 0.2\%$ per bar.

Please note that the control behavior is influenced by substantially different pressure conditions.

2.22 Response Time

The CMOS sensor has a very fast response time of 50 ms. This is available directly at the output signal. In digital communications, the bus size and the speed are far more important in practice.

2.23 Control Behavior

The control behavior can be adapted to suit the application. There are three sets of parameters (slow, medium and fast). At shipment, one set is pre-programmed as User 1, which corresponds to a "medium." You can select these with the RedySmart Smart Interface Portal software.

Modifiable Parameters:

Parameter set A: User 1 (standard, corresponds to parameter set "medium")

Parameter set B: User 2 (corresponds to parameter set "medium")

Fixed Parameters:

Parameter set U: Fast control with low overshoot

Parameter set V: Medium control with minimal overshoot

Parameter set W: Slow control with no overshoot

3. Installation and Commissioning

3.10 Mounting Position and Mounting Location

We always recommend a horizontal mounting position. This can be upright, sideways or upside down. With a vertical mounting position, dependent on the type of gas and at gauge pressures above 5 bar, a zero-point offset can develop. This effect is caused by convection in stationary media.

With regard to mounting location, the following situations can cause problems:

- Strong heat sources, or ambient temperatures outside the specification
- Strong sources of electromagnetic radiation such as spark discharges
- Humid environments and the associated condensation lead to damage of the electronic components
- Particularly in the case of flow controllers, strong vibrations will cause unstable control.
- In general, aggressive environments reduce the service life.
- Liquid running backwards can penetrate into the measuring instrument. An elevated mounting location generally helps or using check valves.

3.11 Requirements for Pipework

The most common causes of problems are the way that devices are connected to the gas supply.

Please note the following points:

- The pipes must be absolutely clean. Please flush them **before** installing the measuring instruments!
- Use appropriate pipe materials (pressure rating, durability)
- Even when connected to fixed pipework, we recommend that the devices are mounted using the appropriate mounting holes
- From 50 l/min, please allow the following flow-calming sections:
- Inlet: 10 x diameter; outlet: 5 x diameter
- Use appropriate fittings (see Chapter 3.13)
- Malfunctions can be caused by unstable pressure controllers, pumps that oscillate, and volumes before and/or after the measuring device that are generally too small. Install an air reservoir with 2 liter volume in the feed pipe.
- The size of the pipe must be matched to the measuring/control device. A diameter that is too small results in an increased pressure drop. From 60 l/min, we recommend a pipe inside diameter of at least 10 mm.
- Please note the grounding connections specified in a separate chapter
- Check for any leaks before commissioning the devices
- For maintenance work, we recommend that a bypass system is used. This is particularly important where the gas supply must not be interrupted

3.12 Sealants

The design of the devices enables sealing at the ends with O-rings or flat seals. It is **essential** that you avoid:

- the use of sealing tape to seal threads. Small pieces can cause incorrect measurements and control-valve malfunctions. As well as that, if the device has to be checked or recalibrated, there will be an extra charge for the additional cleaning work.
- sealing with liquid sealants will incur a higher cleaning charge for cleaning the device in an ultrasonic tank.

3.13 Recommended Filter Fittings:

We are happy to supply the appropriate fittings with 50µ filter. The fittings are designed for end-sealing and have an integral inlet filter.

Types

Part No.	Type/Connections	Material
328-1011	G ¼" to 6 mm	Stainless steel, FKM
328-1012	G ¼" to ¼"	Stainless steel, FKM
328-1013	G ¼" to 12mm	Stainless steel, FKM
328-1014	G ¼" to ½"	Stainless steel, FKM



Pressure loss (air)

Flow rate	Pressure loss G ¼"	Flow rate	Pressure loss G ½"
5 l/min	2.2 mbar	50 l/min	5 mbar
20 l/min	25 mbar	100 l/min	10 mbar
40 l/min	85 mbar	200 l/min	30 mbar
60 l/min	180 mbar	300 l/min	70 mbar
		400 l/min	140 mbar

3.13.1 Installation of Filters

The fittings are supplied in pairs. They should be installed with filter at the inlet and without filter at the outlet.

The fitting with a filter must be installed at the inlet (as determined by the flow direction). The sealing rings (O-rings) must not be damaged during assembly.

For more information, see the [data sheet](#) for the fittings.

3.14 Filters / Gas Cleanliness

We always recommend that a filter, or at least a fine-mesh sieve, is installed before the measuring devices. It often happens that solid matter such as welding residues, metal or plastic chips, rust,

sealing tape, etc. affect the function.

In pressurized-air applications using compressors, the air must be dry and free of oil. Please ensure that a suitable processing unit is located before the devices. In the case of gases from cylinders, no special filtering is needed. For more information, see [Chapter 4 Operation and Maintenance](#).

3.15 Electrical Power Supply

For information on our cables and power supplies, please see the [cable guides and power supply guides on our website](#). If you want to make up the cable yourself, please note the connection diagrams in this manual and the applicable EMC requirements. With power cords more than 3 meters long, use appropriate filter elements. Be aware of possible ground loops if you ground electrically conductive pipes.

	<p>Warning</p> <p>The supply voltage can be in the range +18-30 VDC and should have the smallest possible residual ripple (typically ± 50 mV). Please check that the devices have been correctly wired before you connect them to the appropriate power supply. Unprofessional cable routing can result in troublesome voltage drops.</p>
--	---

3.15.1 Cable for The Analog Signals

Optimal results are only achieved with the right wiring. Exclusively shielded and twisted cable should be used for connection to an analog measuring device (PLC).

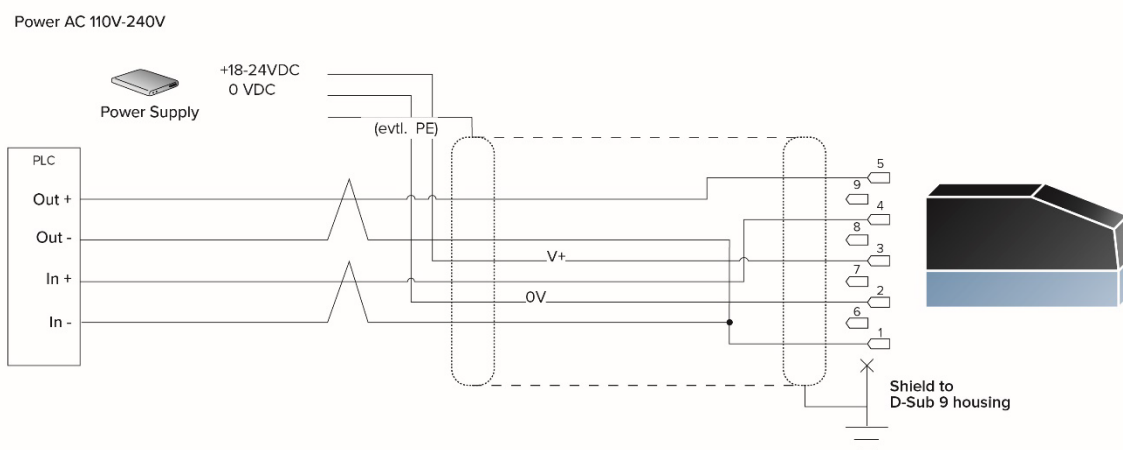

For precise measurements we advise against combining the 0V-supply and comm wires. Please run the cable as shown above in the illustration.

We recommend only the 4-20 mA current measurement. Keep the following in mind for voltage signals: high-ohm voltage inputs are susceptible to troubles (EMC) and long cables produce a voltage drop = measurement error.

3.15.2 Cable for Digital Communication

Again, optimal results can only be achieved with the correct wiring. Use exclusively shielded and twisted cable material for connection to a RS-485 interface.

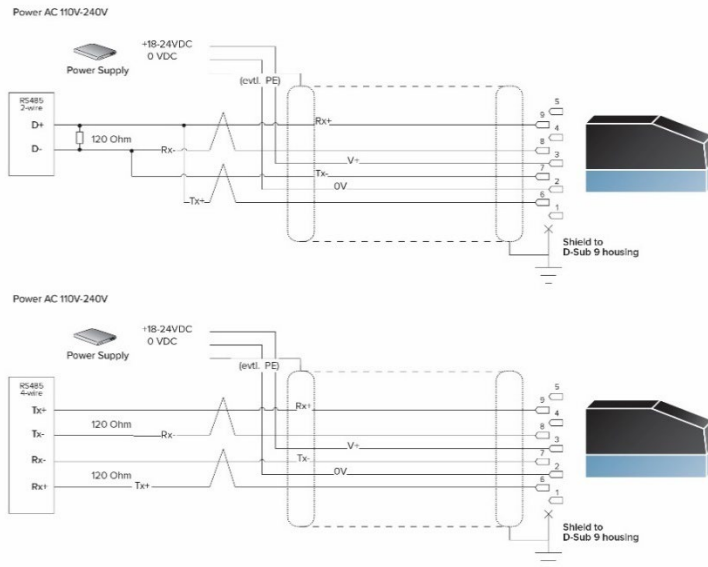

The 120 Ohm resistors are not built into the device. They must be provided externally and are absolutely essential for the RS-485 current loop operation.

The resistors are already integrated in the PDM-U (USB-RS-485 converter) interface from Sierra Instruments, available as an accessory. This interface is ideal for use in the laboratory.

3.16 Grounding

As a ground terminal, please use only the threaded hole shown. Make sure that the meter is grounded before connecting it to the power supply.

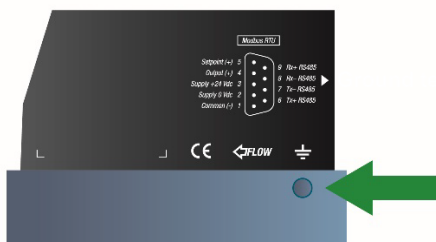

The metallic connector housing is connected to the equipment ground.

	<p>Warning</p> <p>The maximum permissible fault voltage between supply 0 VDC and grounding must not exceed 30Vpeak.</p> <p>The maximum permissible fault voltage between common and grounding must not exceed 30Vpeak.</p>
---	---

3.17 Led Operating Status Display

The operating status of the RedySmart Series can be read from the LEDs.

	<p>Power</p> <p>Illuminates when the device is correctly supplied and operational</p> <p>TxRx</p> <p>If the RxTx LED is flashing, it means the device is communicating on the digital Modbus interface</p> <p>Alarm</p> <p>If the red LED is flashing, there is a malfunction. If the LED is continuously illuminated, there is a serious error and the device must be serviced.</p>
--	---

Flashing Alarm:

- a. **Power-Up Alarm:** The supply voltage to the device has been interrupted.
- b. **No Parameter Values:** No parameters were found.
- c. **Flow at Control Value 0%:** Despite a control value of 0% (Valve completely closed electrically) a flow greater than zero was measured. This can be an indication of a valve that is no longer sealing tight, an internal leak or a zero point offset. This alarm is only active in the case of a flow controller.
- d. **No Flow at Control Value 100%:** Despite a control value of 100% (Valve completely open electrically) no flow was measured. This alarm is only active in the case of a flow controller. When the valve overload protection is switched on an alarm will only be set once. After the acknowledgement of the alarm it will no longer appear until you power on again.
- e. **No Flow Change:** The control value for the valve was lowered or enlarged, but the measured flow does not change. This alarm is only active in the case of a flow controller.
- f. **Analog Input Alarm:** The analog set point is outside the permitted range (21.6mA, or 10.8V)

- g. **Current Input Alarm:** The current at the analog input is too high. It will be switched to the voltage input for 4 seconds in order to protect the circuit. This will be repeated until the current lies within the valid range.



Important Note

If the devices are operated exclusively in analog mode we recommend setting the control mode to Analog. This deactivates the alarm and prevents the flashing of the alarm display after a reset or Power On.

This setting can be performed with the RedySmart Smart Interface Portal Software .

The screenshot shows the 'Analog signal settings' window. The 'Setpoint setting' is 4..20 mA. The 'Measuring value output' is also 4..20 mA. The 'Control mode' is set to 'digital'. The 'Power up-value' is checked for 'On-Off' at 0 min/min. The 'Analog signals' status is 'Enabled'. Below the settings is a table with the following data:

On	Addr	Serial no.	Type-Code	Gas	Reading	Setpoint	Unit	Temp.	Unit	Total	Unit	Gauge identification
▲	247	150000	GSC-69SA-8B26	Air 600	0.0	0	min/min	26.9	°C	55.61	In	

Below the table is a 'Status' bar with 'License:Emulator'.

When the device is in digital **control mode** and the **Startup-Set point** is switched on.

The red LED flashes after the device is powered on (Power On).

In this configuration the device can be controlled exclusively via digital communication. The analog signal for the set point setting will not be evaluated.

The screenshot shows the 'Analog signal settings' window. The 'Setpoint setting' is 4..20 mA. The 'Measuring value output' is also 4..20 mA. The 'Control mode' is set to 'automatic'. The 'Power up-value' is checked for 'On-Off' at 0 min/min. The 'Analog signals' status is 'Disabled'. Below the settings is a 'Regelmodus' dropdown set to 'analog'.

If the device is in automatic or analog control mode, the display of the flashing LED will be suppressed.

3.18 Display

The RedySmart can be equipped with an optional display. The display uses OLED technology with 132 x 64 pixels. Various display modes are possible on a diagonal of about 1 inch.

The display is linguistically neutral and is self-explanatory in both German and English.

The RedySmart controllers have two buttons, one to the left of the display and one to the right. A setpoint value can be specified using these buttons. In order to enable the specified setpoint value, both buttons must be actuated simultaneously until the “EDIT” sign appears in the bottom right-hand corner and the editing mode is activated. A setpoint value can be specified as long as this sign is lit. The value is adopted immediately and set by the controller. The “EDIT” window turns off after a short time. The “EDIT” mode also turns off after a further waiting period.



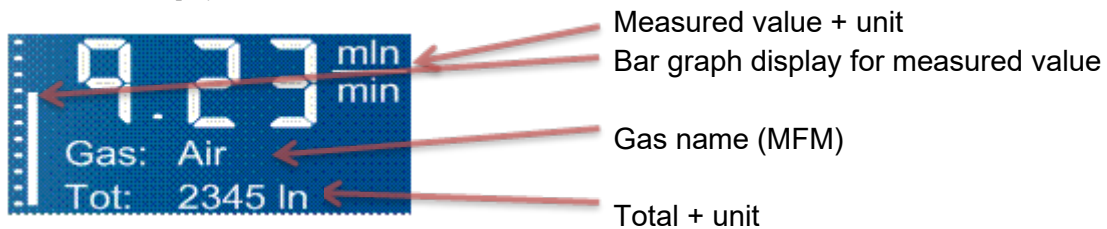

MFC standard display



MFM standard display

Display Sleep Mode

Option implemented since August 2020 to prevent premature ageing of displays

By default, the display automatically switches to sleep mode after one hour if no short press on button ,  or  has been made during that time.

Remark: If you would need to deactivate this display sleep option, please contact Voegtlin Instruments. But be aware that the warranty on your display will be reduced to one year instead of three today.

Various basic display settings can be made using the RedySmart Smart Interface Portal Software on the “Parameters” tab under Options 2 – display:

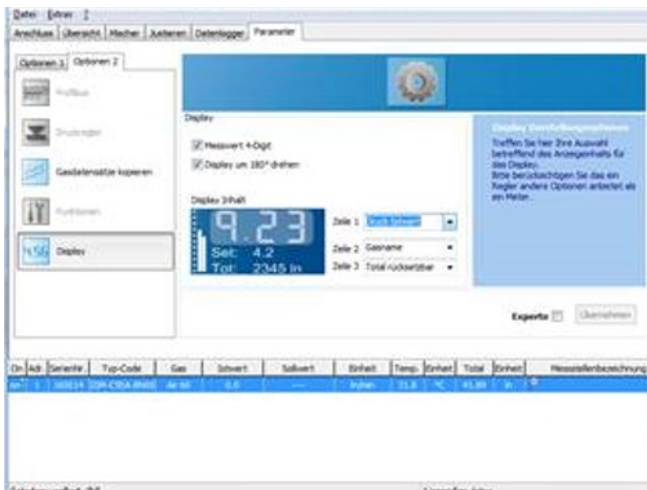

RedySmart Smart Interface Portal Software (MFM)

- 4 digits: a maximum of 4 digits are displayed, standard is 3 digits.
- Rotated by 180° : the display can be rotated by 180°.
- What should be shown on the display and where:
 - Line 1: Actual flow value or Actual pressure value
 - Line 2: Setpoint flow value (MFC only) or Setpoint pressure value (MFC only) or Gas name
 - Line 3: Totalizer resettable or Totalizer or Valve utilization (MFC only) or Actual Flow (for pressure application)

4. Operation and Maintenance

4.10 Warm-Up Time

All instruments of RedySmart line are immediately ready for use. There is no warm-up time.

4.11 Maintenance / Calibration Check

When operated properly, RedySmart devices do not require any routine maintenance. However, we recommend that the calibration is checked after 12 months. If your RedySmart, still within tolerance, this time interval can be extended. The timing of the periodic check is the customer's responsibility.

If you send in your meter, Sierra will evaluate the meter to see it's operational status. The measuring device is recalibrated when it is out of tolerance.

4.12 Cleaning to Remove Contamination

Depending on the type of contamination, on-site cleaning of the measuring or control device may be possible. As a first step, we recommend flushing with N₂ or dry air. If it is contaminated with liquids (ex. oil), pure Ethanol (100%) can be used. Please rinse after cleaning the device with valve position 100% open with dry air or nitrogen for approximately 15 minutes to dry all liquids. With a flow controller, it is helpful if you operate it with the *RedySmart Smart Interface Portal Software* to open the valve. A mechanical opening of the valve is not possible.

To do this, you need an **AC adapter plug and an interface cable**. Please consult your local Sierra representative to purchase or buy from the Sierra Online Store.



Warning

The warranty is null and void if cover was removed.



Warning

- Only use the proper tools.
- Be careful when handling the device and the individual components.
- Make sure that the disassembly environment is clean.
- Never loosen any Torx screws.
- On no account must you touch the circuit board or electronic components without first grounding yourself and the surroundings. Electrostatic discharges can destroy components.
- After cleaning, you should have the device checked or if necessary recalibrated by your sales partner at the next opportunity.

4.12.1 Flow Splitter Disassembly

If the basic body has become contaminated the flow splitter can be removed. The removal should only be done by trained service personnel. Disassembly is different for the different device types:

The fourth letter of the article code defines the type of the flow splitter. For example: GSC-B9-BB22 contains a flow splitter of the type B.

Type A

- First release the slotted screw in the center of the flow splitter (approx. 5 turns)
- Unscrew the whole flow splitter with an Allan key

Type B, C

- Unscrew the whole flow splitter with an Allan key

Type D (G ½")

- First unscrew the locking pin (underside of the body) with an Allan key
- Unscrew the flow straightener with a suitable tool
- Pull the flow splitter out of the body
- Flow splitter assembly
- Carry out the steps described above in reverse order
- After correct assembly flush RedySmart with dry inert gas.
- Check that the cleaned measuring device is functioning correctly by checking the zero point and some defined measurement values, for example.

4.13 Return

When returning a measuring or control device, use the original packaging if possible, or other suitable packaging. So that we may serve you quickly, we would be grateful if you briefly describe the possible causes of the faults.

	<p>Warning! If the device has come into contact with aggressive or toxic gases, please ensure that it is properly cleaned/flushed before returning the device to us. Please always complete the contamination declaration form. You will find these in the appendix or in the enclosed CD.</p>
---	---

4.13.1 Recalibration

It is mandatory to recalibrate the instrument after an expansion of the flow splitter.

5. RedySmart Smart Interface Portal Software (SIP)

5.10 Introduction

RedySmart Smart Interface Portal Software (SIP) is configuration software that allows you to easily check and modify device parameters. In addition, you can use RedySmart Smart Interface Portal Software to check your interface wiring, depict the bus structure, and modify device addresses if necessary.

We provide the RedySmart Smart Interface Portal Software free of charge at sierrainstruments.com/redysmart-software. RedySmart Smart Interface Portal Software runs on computer systems with the Windows 10/7/XP/NT/2000/98 operating systems.

5.11 Installation

After downloading the software, you can choose which programs you want to install, and which manuals you want to open.

5.12 Functions

The RedySmart SIP provides the following function blocks for you:

- Configuration of the serial computer interface
- Setting the program language
- Scanning and depicting the bus structure
- Integrating individual devices into the bus structure
- Reading the device-specific hardware and software versions
- Displaying the reading, the totalizer and temperature for each device
- Resetting the totalizer
- Setting the setpoints
- Selecting the control parameter sets
- Setting the PID control parameters and checking performance
- Selecting the active gas type
- Optional data logging (price add-on)
- Optional gas mixture (price add-on)

5.13 On-Screen Help

Within the program, the functions are described in the “Help” menu.

5.14 Digital Communication

For detailed information on the digital interfaces, see the separate RedySmart Digital Communications Instruction Manual. You can download the manual at sierrainstruments.com/redysmart-digicom-manual.

6. Pressure Control

This part of the operating instructions describes the device model with the function of the pressure control with simultaneous flow measurement.

For the pressure control function, a pressure transmitter with a linear analog output signal is included. Optionally, an existing pressure transmitter or sensor (e.g. pH, temperature, humidity, CO₂-content, etc.) with the same output can be incorporated.

6.10 Characteristics

The great flexibility of this pressure controller is shown in the following functions/characteristics:

- Can be used as flow meter, flow controller or pressure controller. (The functions of flow or pressure controller can be interchanged.)
- Can be changed over from back pressure control to pressure control
- The adjustable flow limitation is used to determine the rate of pressure increase. In addition, this function - in conjunction with a pressure-controlled gas mixer - is recommended to ensure that the control valve does not drive the system over the device's maximum full-scale value. (Master-Slave function)
- Very wide dynamic range (e.g. up to 1:500) with pressure control, and high resolution of the flow signal.
- Adjustable PID parameters for optimizing the process

6.11 Description of The Application

In various processes, a certain volume has to be controlled to a defined pressure. In a closed system, temperature fluctuations have a major influence on the stability of the pressure. When a gas is compressed it heats up, and conversely it cools down when pressure is released. So that the pressure can be controlled in a stable manner, there must be a certain consumption of the gas. The leakage flow can be set with a precision control valve.

6.12 Requirements

- To ensure the correct function, a pressure transmitter with a linear output signal from 0-5/10 V or 0/4-20 mA is required.
- All communication takes place solely through the digital interface. The Modbus RTU interface is standard. Profibus DP is also available as an option. The GSD file required for Profibus can be downloaded from our website:
<https://www.sierrainstruments.com/products/downloads/redy-smart>
- Optionally, the analog actual value of the flow can be read.

6.13 Pressure Control (Pressure Controller, GSP)

The classic application of pressure control. A process must be controlled to a certain pressure, independently of the gas consumption. To enable the pressure to be adjusted, gas must be continuously supplied to, and discharged from, the process.

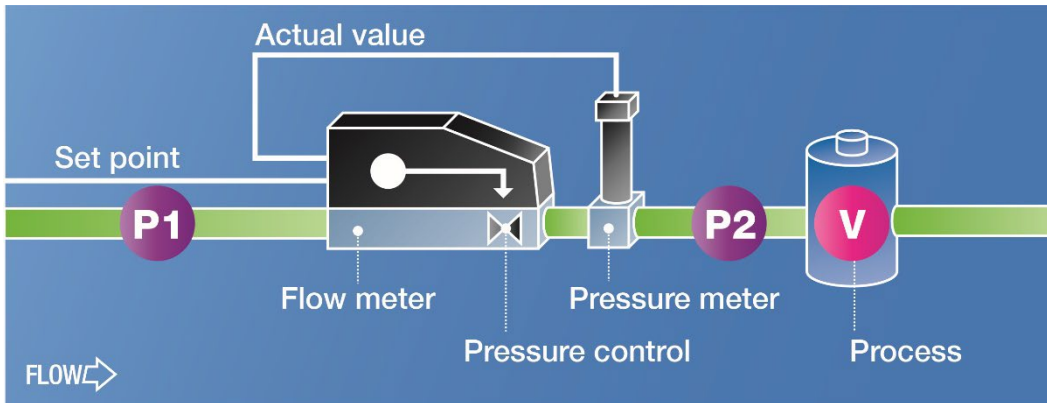

The pressure at the inlet of the pressure controller is higher than the pressure in the process i.e. the pressure that is to be controlled.

The control valve opens when the process pressure is too low.

6.14 Back Pressure Control (Back Pressure Controller, GSB)

In the case of back pressure control, the process itself generates a gas flow/pressure, and gas is continuously drawn off. In this setup, the control valve is situated after the process, so we talk here of an “overflow”.

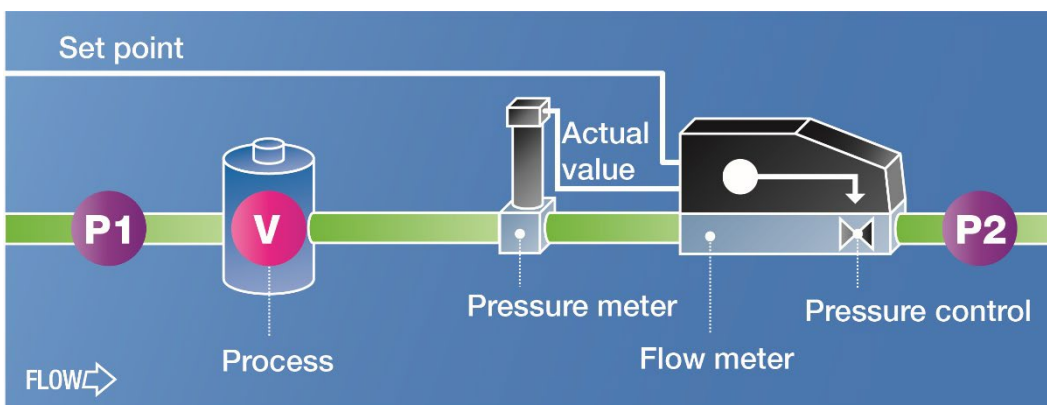

The pressure at the outlet of the pressure controller is lower than the pressure in the process i.e. the pressure that is to be controlled.

The control valve closes when the process pressure is too low.

Basically, it is also possible to control other parameters such as pH, temperature, humidity, CO₂-content, etc. The operation of the control valve is all-important in this context. Please contact your Sierra representative to discuss the feasibility.

6.15 Technical Data

Versions: Pressure control, dynamics 1:10 (up to 1:100 depending on application)
 Back pressure control, dynamics 1:5
 Differential pressure control (customer-specific)

Control Pressure Ranges:

Over-pressure

0.5 bar gauge pressure (7.25 psig)
 1 bar gauge pressure (14.50 psig)
 2 bar gauge pressure (29.01psig)
 5 bar gauge pressure (72.52 psig)
 10 bar gauge pressure (145.04 psig)

Absolute pressure

1.2 bar a (17.40 psig)
 2 bar a (29.01 psia)
 5 bar a (72.52 psia)
 10 bar a (145.04 psia)
 Customer-specific

6.16 Block Diagram

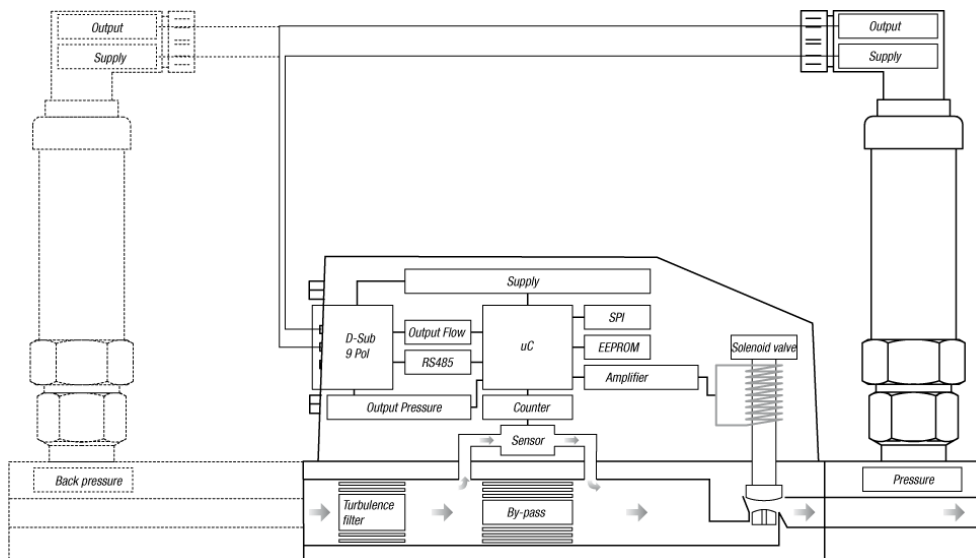

6.17 Electrical Power Supply

The analog output signal of the pressure transmitter is fed to the setpoint input of the pressure controller. The pressure setpoints are set entirely digitally. For existing pressure transmitters, the system can also be changed over to voltage input. The analog output signal from the pressure transmitter can be connected via the terminals of the Bus-Analog Modules (BAM). See [Cable Information Guides](#).

6.18 Connection Diagram

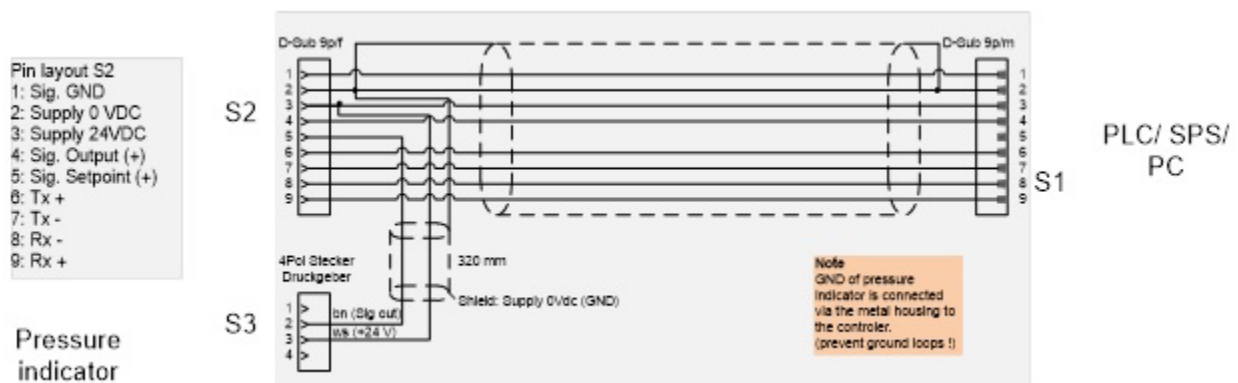

Customer's Pressure Transmitter / Sensors



Warning!

Sierra Instruments makes no guarantee regarding function when operating with pressure transmitters / sensors from customers.

6.19 Settings for Control Parameters

The control loop for the pressure control is a classic PID control action. Practical experience has shown that most applications with PI controller settings exhibit good control quality. We recommend that your setup should tend towards slow control. Although slow control has the disadvantage in the case of setpoint jumps that the controller responds slightly more slowly, it significantly increases the control stability and reduces the dynamic behavior of the controller. We also recommend (dependent on the application) that you use a compressed air reservoir (dead volume) between the pressure controller and the process.

You can activate five different PID control sets in the device. All sets are factory-set to identical parameters. It is recommended not to change PID control set 1 so that you can return to the

original setting at any time.

Practical experience shows that the Ki setting has the strongest influence on a stable control action. We suggest Kp values between 200-2000 and Ki values between 5-50. The process for setting the control loop is described next. To optimize the control loop, assemble the complete system and connect the pressure controller with a PDM-U cable to your PC. Start the RedySmart operating software and activate the “Graph” menu. Set the flow conditions (leakage rates, etc.) in conformance with your operating conditions.

Order	Action
Basic settings	<ul style="list-style-type: none"> • Select the appropriate PID control parameter set in the “Graph” menu. • Set the values Ki and Kd to zero. • Set up the test arrangement so that it corresponds approximately to the real application. Pay particular attention to the dead volume and the leakage flow. These two parameters have a sustained influence on the control behavior.
Setting Kp	<ul style="list-style-type: none"> • Use the setpoint inputs now to specify a setpoint jump. Now work with setpoint jumps of between 0 - 75%. • Increase the value Kp until the actual value of the pressure in the graph oscillates with a regular, even waveform. This may require more or less variation with respect to the setpoint. • With each change in the Kp value, perform a new setpoint jump away from zero so that you can make a better judgment about the change.
Setting Ki	Now increase the Ki value step by step. At the optimum setting, the pressure will stabilize. The setpoint and actual value are now identical. As a general rule, Ki values between 5-20 give the best results.
Setting Kd	The differential share of the PID controller is not necessarily set in factory (value = 0).
Checking	Test the control behavior now with different flow rates and pressure setpoints which might be encountered in your application. You may need to adjust the control parameters slightly. We recommend that you change both parameters by the same factor.

6.20 Configuration With the RedySmart Smart Interface Portal Software

With *RedySmart Smart Interface Portal Software (SIP)*, you can connect a pressure controller directly to your PC and operate it. The only accessories you need are a USB converter cable (PDM-U) and an AC adapter plug. ([See data sheet cables, power supply](#)). You can find the RedySmart SIP software on our website sierrainstruments.com/redysmart-software as free download. After installation, you can specify a pressure setpoint and read the current values of pressure and flow.

Please note for the configuration of the pressure regulator the relevant section in the manual of the get RedySmart SIP software.

6.21 Pressure Conversion Table

Conversion table for devices of pressure:

	bar	mbar	PSI	Pa	hPa	Torr
1 bar =	1	1000	14.50377377	100'000	1000	750
1 mbar =	0,001	1	0,01450377	100	1	0.75
1 PSI =	0.068947	68.947	1	6894.8	68.948	51.715
1 Pa =	0,00001	0,01	0.0001450377	1	0,01	0.007500
1 hPa =	0.001	1	0.01450377	100	1	0,75
1 Torr =	0.00133322	1,33322	0.01933	133.32	1.333	1

7. Appendix

7.10 Troubleshooting

In the following table we have compiled fault symptoms, their possible causes and suitable measures. If you do not recognize your fault symptom, or the proposed measures were not successful, please consult Sierra <https://www.sierrainstruments.com/techsupport/techsupport.html>.

If you are planning to return a product, please refer to [section 4.13](#).

If you have to remove the measuring or control device from the pipeline, please observe any flushing procedures and the relevant safety guidelines.

You will find a guide on how to remove and clean the devices in the chapter “Operation and maintenance”.

7.11 Measurement & Control of Flow Rate

Error	Possible Causes	Measures
Output signal is larger than the setpoint	Valve is contaminated and cannot close fully	Flush the valve by repeated “Valve 100%” open/close in the RedySmart SIP software under “Signals”. Please contact Sierra.
	The setpoint and actual-value signals were set differently, ex. setpoint 0-20 mA / actual value 4-20 mA	Operate the device with the RedySmart SIP software. The setpoint and actual values can be changed in “Signals.”
Output signal is smaller than the setpoint	The gas supply is too low. The counter pressure is too high	Increase the inlet pressure. Check the valve voltage in the RedySmart SIP software. This must not be > 95%. (In menu “overview” click the button “Graph” or in the main menu /Extras /Graph Tool)
Analog setpoint is not acquired	Incorrect electrical connection	Please check that the pin assignments are correct.
	The control mode is set to “Digital”	Change the control mode to “Automatic” or “Analog” in the “Signals” window of the RedySmart SIP software
	Wrong analog signal	Operate the device with the RedySmart SIP software. The analog setpoint and actual values and the unit can be changed in “Signals.”
	Device is being simultaneously operated with the RedySmart SIP software; digital communication has priority	Close RedySmart SIP or change the control mode to “Analog” in the “Signals” window of the RedySmart SIP software.
Analog output stays at 4 mA or 0/1 V	Switch-on setpoint has been activated	Change the switch-on setpoint in the menu “analog signal”. Below this set value, the device shows zero flow.

Error	Possible Causes	Measures
Output signal is 21.6 mA / 5.4 or 10.8 V (only with measuring devices)	Flow is too high (Overflow)	Reduce the flow rate. If necessary, the full scale can be extended on site. Please contact Sierra.
	Device is heavily contaminated	Please contact Sierra.
	Sensor faulty	Please contact Sierra.
Flow is shown despite setpoint zero	Valve is leaking, contaminated	Flush the valve by repeated "Valve 100%" open/close in the RedySmart SIP software under "Signals." Please contact Sierra.
	Sensor contaminated	Please contact Sierra.
	The device is being operated with a different gas from its calibration	For multi-gas instruments, you can set the appropriate gas type with the RedySmart SIP software
	Offset due to mounting position	Particularly with small measurement ranges, heavy gases and gauge pressures > 5 bar, a zero-point offset can occur where the mounting position is vertical >> chimney effect. Where possible, mount the device horizontally
	"Power-up" setpoint is enabled	In this case the device controls to a defined setpoint as soon as it is powered with 24 V. Disable the "power-up" setpoint or enter a setpoint value 0
No digital communication is possible	Several devices with the same address have been connected to a bus. During operation, the address of several devices was changed with the "All address 247" button	Connect one device after another to the RedySmart SIP software and assign the device addresses
	The power-supply device is too weak to power several devices simultaneously	Use a power supply with a higher power rating (see datasheet 329-3010_ml_cablePSD.pdf "Power Supply Devices"). Please contact Sierra.
	You are working with devices from different generations Serial number < 110,000 Smart 3 Serial number > 110,000 Smart 4	In mixed-mode operation, only the PDM-U digital cable with USB port can be used
	The USB port has not been assigned	Assign the correct COM port in the Device Manager on your computer.  Warning: Do not go higher than 9!
	The baud rate has been changed	The RedySmart SIP software only works with a baud rate of 9600
	You are working with an interface converter that may require level matching	Refer to the connection diagram for the Smart digital connection. Please contact Sierra.

Error	Possible Causes	Measures
	Faulty circuit board	Please contact Sierra.
No flow, despite the setpoint being above zero	The control mode is set incorrectly	Change the control mode to "Automatic" in the "Signals" menu
	There is no gas flow or pressure	Open the gas supply, or check the inlet and the outlet pressure
	The control parameters are not set correctly	In menu "overview click the "Graph Tool" menu, or in the main menu under Extras/"Graph Tool", a window will open with which the control parameters can be reset. As shipped from the factory, the parameters are already set Default settings: N = 2000 KP = 1000 Ki = 600 Kd = 0
After about 10 seconds, the controller "clicks" clearly audibly at short intervals	There is no gas flow, although a setpoint is being applied	Ensure that gas can flow; check the inlet and outlet pressure
Control is unstable	Pressure reducer is faulty, not suitable for the control range, or of poor quality	Use a buffer volume after the pressure reducer as a buffer, or a suitable pressure reducer
	Process pressure fluctuates greatly	Use a buffer volume after the pressure reducer.
	Gas supply with pulsating pump	Use a buffer volume after the pump as a buffer or choose a pulsation-free pump.
	Outlet pressure too high	Check your process pressures before and after the device
	Buffer volume is too small	Use a larger buffer volume
	Power-supply device is faulty or not suitable	Particularly in the case of devices with serial numbers < 110,000, unstable power supplies can result in malfunctions.
	Control parameters are not optimal	Correct the control parameters in the "Graph Tool" menu as follows: In the case of excessive overshoot: <u>reduce Kp</u> Too slow: <u>increase Kp</u> General oscillation: <u>reduce Ki</u>
Contamination	Flush the valve by repeated "Valve 100%" open/close in the RedySmart SIP software under "Signals". Please consult your sales partner	

Error	Possible Causes	Measures
	Wrong flow direction	Please check the flow-direction indicator on the back of the body
	Potential differences	Please refer to the "Grounding" section in the guide
Flow rate does not meet expectations	Leakage	Flow rate > than reference Leakage between measuring device and your reference Flow rate < than reference Leakage upstream of the measuring instrument
	Contamination	With contamination by sealing tape, for example, it is possible that the flow divider is partially blocked. In this case the device displays more than the reference. Please contact Sierra.
	The device is being operated with a different gas than calibrated.	Connect the intended gas, or change the type of gas in the "Calibration" menu
	Inlet pressure is too low	Check your inlet and outlet pressures
Device becomes very warm	There is a setpoint signal at the flow controller, although no gas is connected	<ul style="list-style-type: none"> - check the pressure in your gas supply - set the setpoint to zero or enable the "detector behavior" in the RedySmart SIP software (default setting for new device)
Valve opens to 100% with each setpoint, no flow is displayed, or the displayed flow remains constant	Sensor is faulty	Please contact Sierra.
Pulsating control after setpoint is applied	Wrong flow direction	Please note the flow-direction indicator on the back of the body

7.12 Pressure Control

The following possible fault symptoms and recommendations are specific to the pressure controller. They supplement the above fault-finding section. We highly recommend using the RedySmart SIP configuration and operating application for diagnosis and possible remedy of errors. Please check if you are working with the current version. Your Sierra representative will gladly assist you.

Error	Possible Cause	Measures
No measured value display for pressure	Connection	Check: <ul style="list-style-type: none"> • 24 VDC power supply available • Plug on the pressure transmitter correctly seated / fitted • Correct connection to the D-sub device plug connector
	Design / device parameters	Check: <ul style="list-style-type: none"> • Correct analog signal design. Compare the data on the nameplate with the settings in RedySmart SIP under "Signals" • Correct scaling of the pressure signal? Zero point and limit value in RedySmart SIP must agree with the measurement range of the pressure transmitter. • Is the device defined as a pressure controller? (The pressure control menu option appears in RedySmart SIP). • The pressure controller is being operated as a back pressure controller, or the other way around.
No gas flow despite pressure setpoint	Gas supply	Check: <ul style="list-style-type: none"> • Is gas available? The device supplies information about the flow. • The pressure controller is being operated as a back pressure controller, or the other way around.
	Setting the parameters	Check (using RedySmart SIP): <ul style="list-style-type: none"> ⇒ The pressure controller is being operated as a back pressure controller, or the other way around ⇒ Control mode must be set to "automatic" or "digital". ⇒ Set values greater than zero in the PID control parameters

<p>The controller fails to reach the preset setpoint</p>	<p>Valve 100% open (in the case of back pressure control possibly 0%)?</p>	<p>The opening rate of the control valve is displayed in the Graph submenu (0 – 100%). Check:</p> <ul style="list-style-type: none"> • It is possible that the leakage flow is greater than the maximum possible flow of the pressure controller. Reduce the leakage flow. If necessary, a control valve (of the pressure controller) with a higher flow rating must be used. • The specified pressure conditions at the input (pressure control) or on the output (back pressure control) are not met. • The gas supply itself is not delivering the required flow to reach the pressure setpoint. Check the measured value of the flow . • Check whether the gas used complies with the specified gas. • In the case of back pressure control, check whether the process is basically able to produce a higher pressure than the desired setpoint pressure. Only then can the back pressure controller operate correctly and allow a bypass flow. • Check the whole system for leakages. When valves are fully closed, and the gas supply is switched off the system must remain constant.
<p>Control unstable</p>	<p>Control parameters</p>	<p>Based on the specified application data, the PID control parameters are preset at the factory and the control characteristics are then checked. Depending on the situation, it may be necessary to adapt the PID control parameters. Check mainly the Ki value. The characteristics are described in the Controller Settings chapter. Try if possible, to maintain the specified application data (particularly buffer volume).</p>
	<p>Interference</p>	<p>Pulsing elements such as pumps or control loops connected immediately upstream or downstream (pressure reductions, flow controllers) can affect stability of the pressure control. If two control loops connected in series exhibit similar characteristics, the systems will mutually build-up as a result. This situation can be eased by using a sufficiently large buffer volume between them.</p>
<p>Unstable measured pressure value</p>	<p>Pulsations, insufficient resolution of analogue signal</p>	<p>Check the stability of the pressure with another manufacturer's pressure measuring device. Enter a higher filter level (see page 18, bottom)</p>

7.13 Pressure Loss

The following figures show the pressure drop of a GSM (measuring instrument)
Type A, B, C, D relates to the built-in GSM flow divider. See p.20

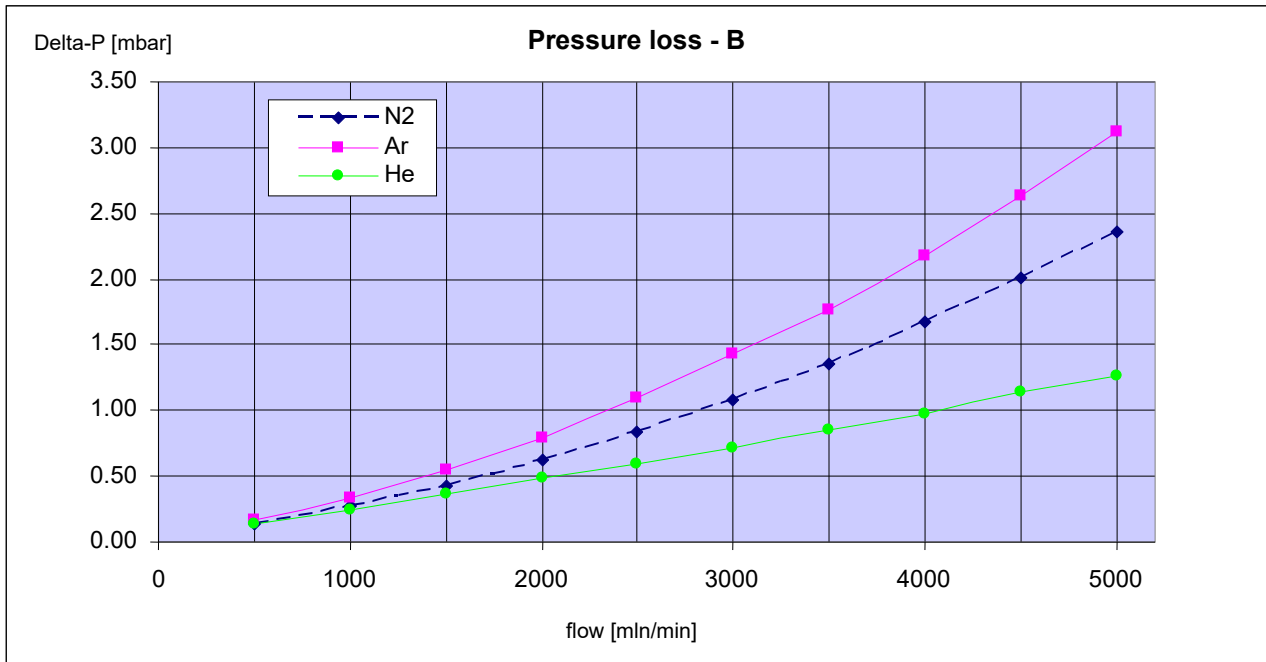
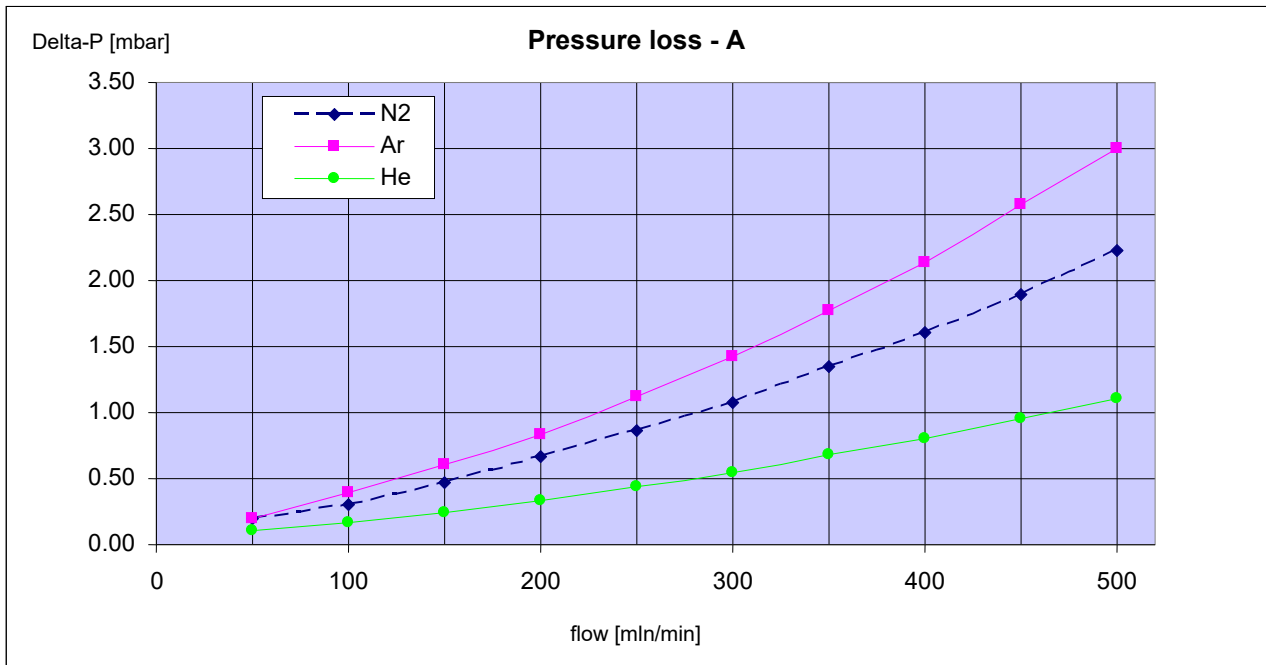

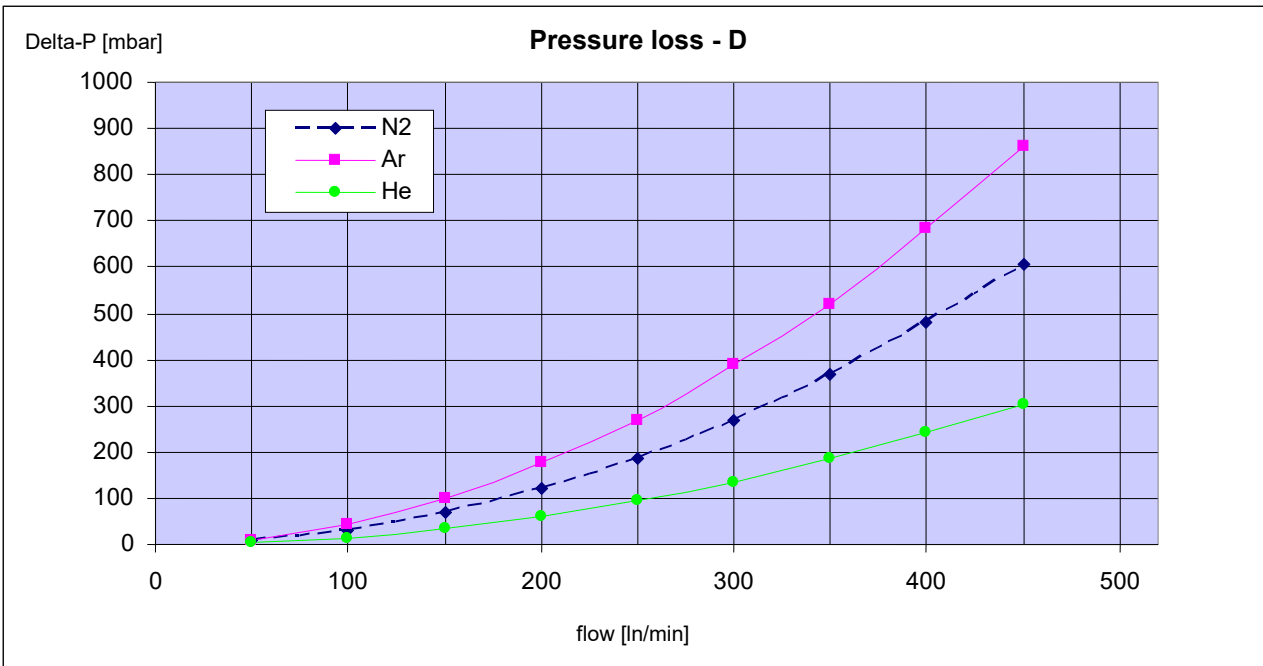
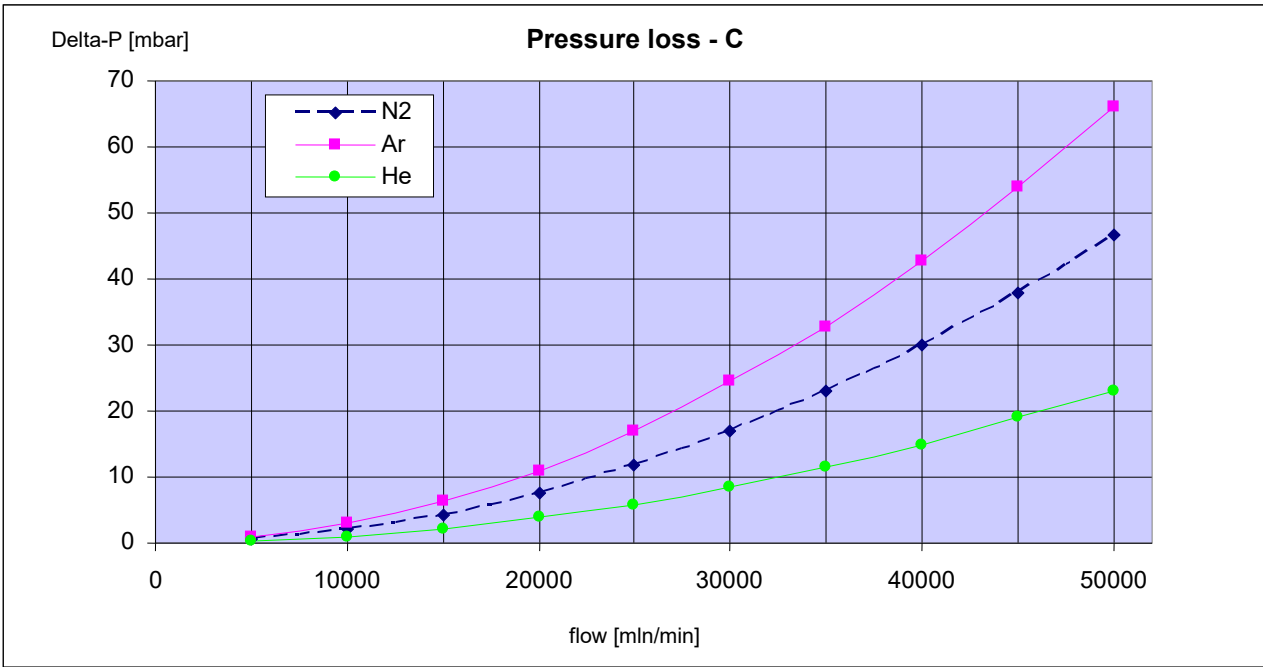

7.14 Dimensional Drawings

GSM, Types A, B, C

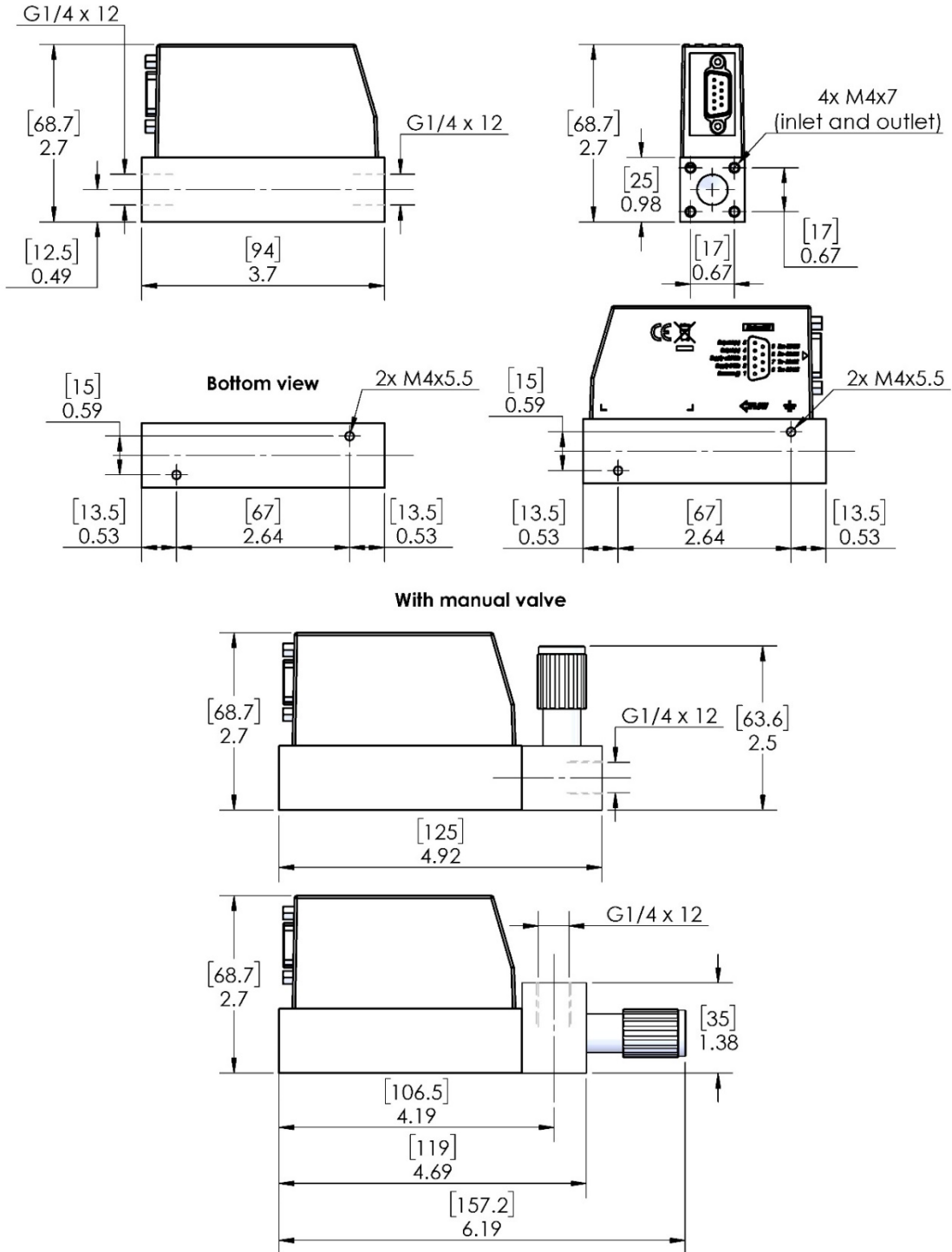

GSC, Types A, B, C

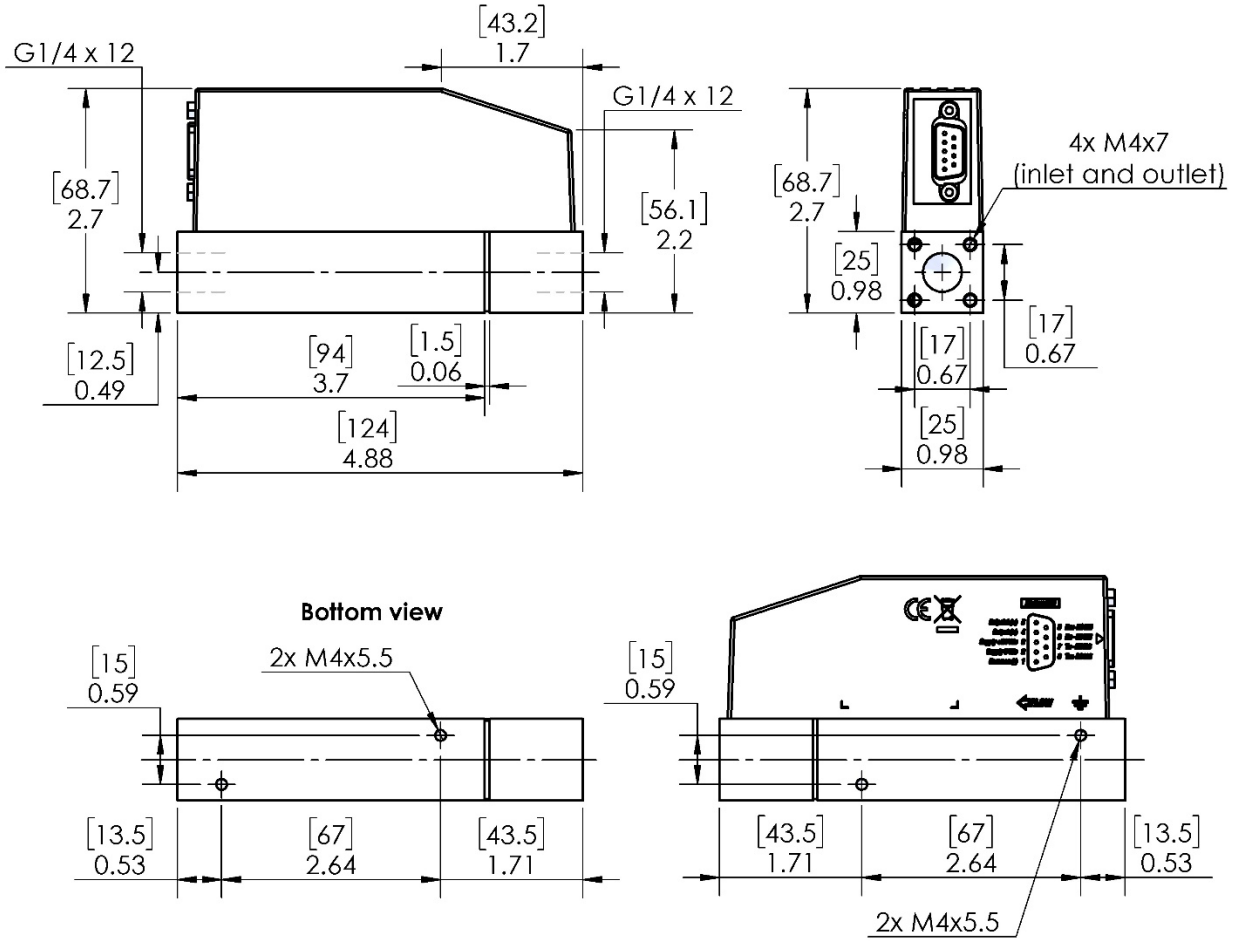

GSM, GSC, Type D

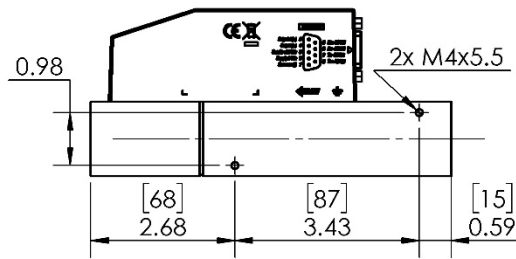
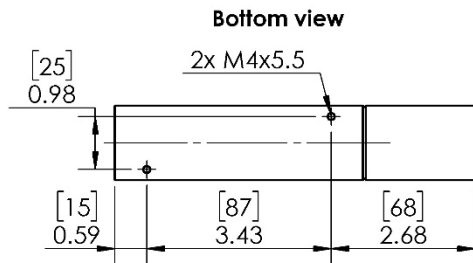
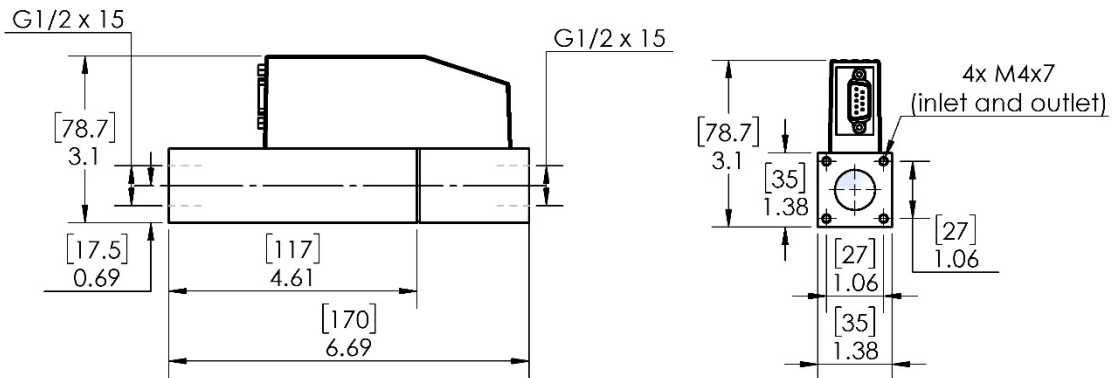
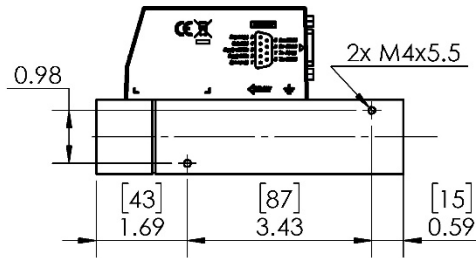
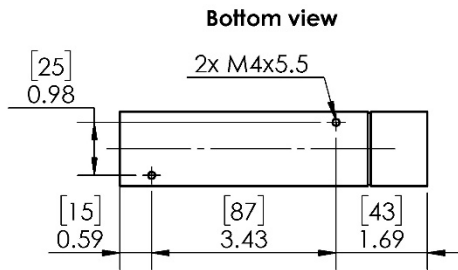
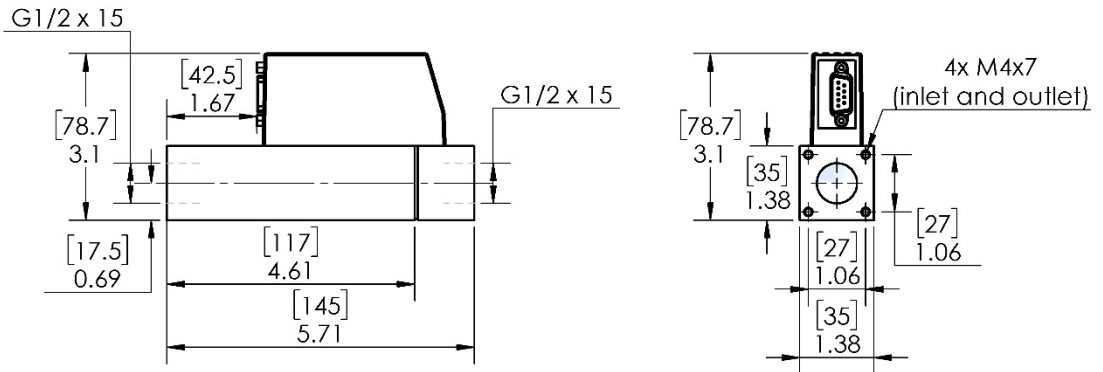

GSC, Type D, With Valve Type 8.0 (Double Valve)

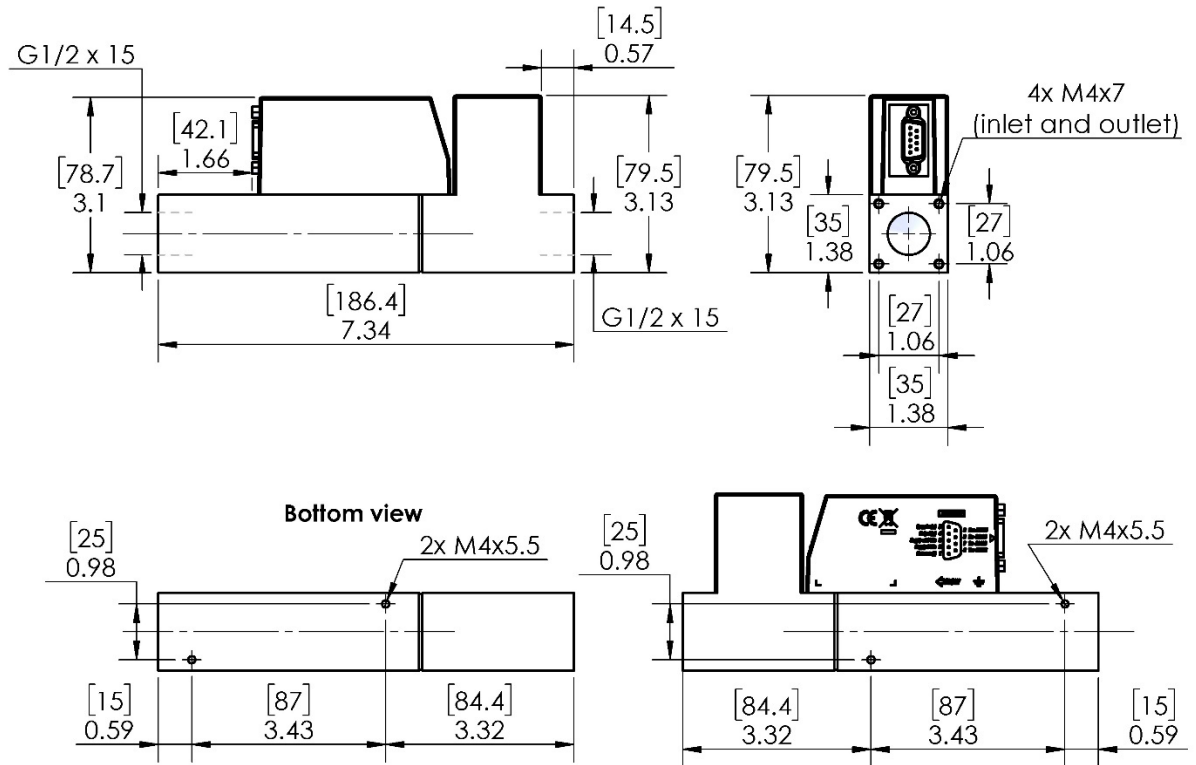

GSP



Note

Dimensions for underside mountings / inlets and outlets, see **GSC type A, B, C.**

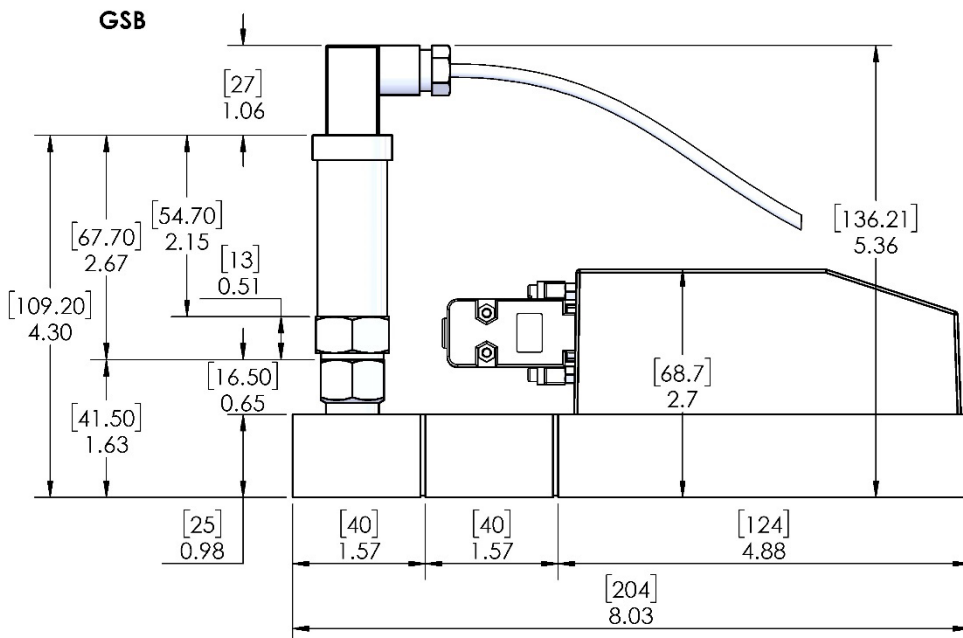
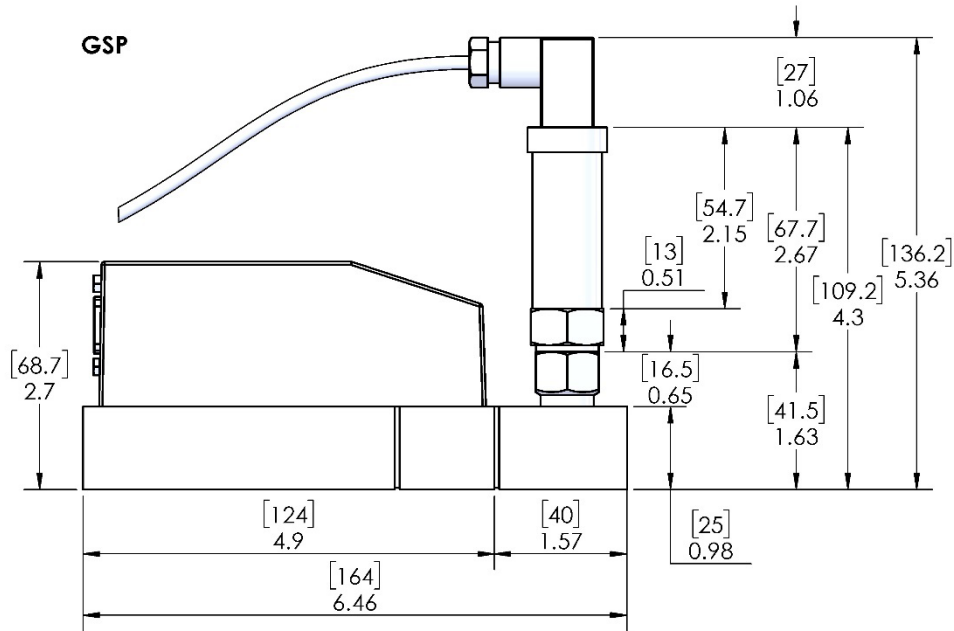

7.15 Accessories

7.15.1 General Information

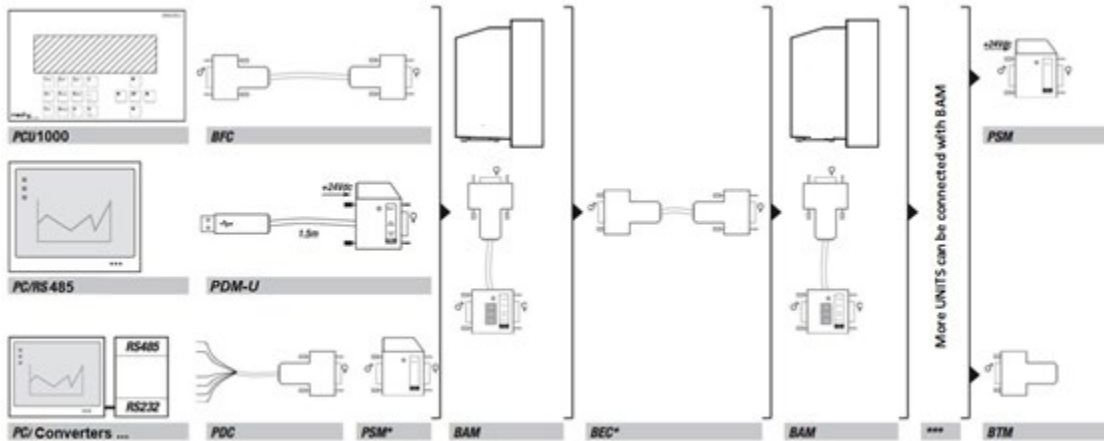

You can find detailed information for the individual products on our homepage <http://www.sierrainstruments.com>

7.16 Communication Cable PDM-U

7.16.1 Driver Installation

- The driver can be from [RedySmart Docs & Downloads page](#).
- Connect the communication cable to the USB port.
- Windows will automatically detect a new **USB device** and request a driver.
- Specify the driver location (directory on hard disk)
- If warning is displayed regarding missing driver certification, please ignore it and continue!
- Windows automatically detects a new **serial port** and requests a driver.
- Specify the driver location (directory on hard disk)
- If warning is displayed regarding missing driver certification, please ignore it and continue!

Installation of the communication cable is complete.

7.16.2 Changing The COM Port

In some cases, the communication cable is installed with a very high COM port number. The current version of RedySmart SIP supports ports up to COM10. It may therefore be necessary to rename the COM port.

- Call up the Control Panel and select System
- Select Device Manager
- Select ports (COM and LPT)

- Select USB Serial Port (COMx), Properties, Port Settings, Advanced
- A new COM port can be selected here
- The serial port is now active under the new COM port.

7.17 Type Code GSM / GSC

																Flow splitter	Measuring range	Instrument versions	Materials (body, seals)		Analog signals (output)	Analog signals (setpoint)	Control valve (integrated)	Control valve (integrated)
Instrument type	RedySmart series (gas)		G	S																				
Function	Meter								M															
	Controller								B															
Full scale of measuring range (air)	25 mln/min (G¼", 25 x 25 mm)														A	1								
	50 mln/min														A	2								
	100 mln/min														A	3								
	200 mln/min														A	4								
	500 mln/min														A	5								
	Customer-specific (divider A, up to 600 mln/min)														A	9								
	500 mln/min (G¼", 25 x 25 mm)														B	2								
	1"000 mln/min														B	3								
	2"000 mln/min														B	4								
	5000 mln/min														B	5								
	Customer-specific (divider B up to 6000 mln/min)														B	9								
	5 lln/min (G¼", 25 x 25mm)														C	2								
	10 lln/min														C	3								
	20 lln/min														C	4								
	50 lln/min														C	5								
	Customer-specific (divider C, up to 60 lln/min)														C	9								
	50 lln/min (G½", 35 x 35mm)														D	2								
	100 lln/min														D	3								
	200 lln/min														D	4								
	450 lln/min														D	5								
	Customer-specific (divider D up to 450 lln/min)														D	9								
Instrument versions	Standard (±1.0% full scale, 1 : 50)																S							
	Hi-Performance (±0.3% full scale, ±0.5% reading, 1 : 100)																T							
	Customer-specific / OEM																K							
Materials (body, seals)	Aluminum, FKM**																	A						
	Aluminum, EPDM																	B						
	Stainless steel, FKM																	S						
	Stainless steel, EPDM																	T						
	Customer-specific / OEM																	K						

		Flow splitter	Measuring range	Instrument versions	Materials (body, seals)	Analog signals (output)	Analog signals (setpoint)	Control valve (integrated)	Control valve (integrated)
Analog signals (output)	Current 4-20mA**					B			
	Current 2-10 mA					C			
	Voltage 0-5 V					D			
	Voltage 1-5 V					E			
	Voltage 1-10 V					F			
	Voltage 2-10 V					G			
	Customer-specific / OEM					K			
Analog signals (setpoint)	Current 4-20 mA**						B		
	Current 0-20 mA						C		
	Voltage 0-5 V						D		
	Voltage 1-5 V						E		
	Voltage 0-10 V						F		
	Voltage 2-10 V						G		
	Customer-specific						K		
Control valve (integrated)	Type 0.1							2	1
factory-set	Type 0.2							2	2
	Type 0.5							2	3
	Type 1.2							2	6
	Type 4.5							1	2
	Type 8							1	3
	Control valve not coded/defined							8	8
	Valve mounted							9	5
	Customer-specific / OEM							9	9
	No valve							0	0
Type code		G	S	-					

**Standard

7.18 Type Code Pressure Controller GSB / GSP

																					Flow splitter	Measuring range	Model (flow rate measurement)	Materials (body, seals)	Analog flow signals (output)	Analog signals (pressure)	Control valve (integrated)	Control valve (integrated)
Instrument type	RedySmart series (gas)	G	S																									
Function	Pressure controller																											
	Back-pressure controller																											
	With external pressure transmitter																											
End value of the flow measuring range (air)	25 mln/min (G¼", 25 x 25 mm)																					A 1						
	50 mln/min																					A 2						
	100 mln/min																					A 3						
	200 mln/min																					A 4						
	500 mln/min																					A 5						
	Customer-specific (divider A, up to 600 mln/min)																					A 9						
	500 mln/min (G¼", 25 x 25 mm)																					B 2						
	1"000 mln/min																					B 3						
	2"000 mln/min																					B 4						
	5000 mln/min																					B 5						
	Customer-specific (divider B up to 6000 mln/min)																					B 9						
	5 ln/min (G¼", 25 x 25mm)																					C 2						
	10 ln/min																					C 3						
	20 ln/min																					C 4						
	50 ln/min																					C 5						
	Customer-specific (divider C, up to 60 ln/min)																					C 9						
	50 ln/min (G½", 35 x 35mm)																					D 2						
	100 ln/min																					D 3						
	200 ln/min																					D 4						
	450 ln/min																					D 5						
	Customer-specific (divider D up to 450 ln/min)																					D 9						
Model (flow rate measurement)	Standard (±1.0% full scale, 1 : 50)																						S					
	Hi-Performance (±0.3% full scale, ±0.5% reading, 1 : 100)																						T					
	Customer-specific / OEM																						K					
Material (body, seals)	Aluminum, FKM**																						A					
	Aluminum, EPDM																						B					
	Stainless steel, FKM																						S					
	Stainless steel, EPDM																						T					
	Customer-specific / OEM																						K					

		Flow splitter	Measuring range	Model (flow rate)	Materials (body, seals)	Analog flow signals (output)	Analog signals (pressure)	Control valve (integrated)	Control valve (integrated)
Analog flow signal (output)	Current 4-20mA**					B			
	Current 2-10 mA					C			
	Voltage 0-5 V					D			
	Voltage 1-5 V					E			
	Voltage 1-10 V					F			
	Voltage 2-10 V					G			
	Customer-specific / OEM					K			
	Analog signals (Pressure transmitter)	Current 4-20 mA**						B	
	Current 0-20 mA						C		
	Voltage 0-5 V						D		
	Voltage 1-5 V						E		
	Voltage 0-10 V						F		
	Voltage 2-10 V						G		
	Customer-specific						K		
	Control valve (integrated)	Type 0.1							2 1
defined by manufacturer	Type 0.2								2 2
	Type 0.5								2 3
	Type 1.2								2 6
	Type 4.5								1 2
	Type 8								1 3
	Valve not defined								8 8
	Valve mounted								9 5
	Customer-specific / OEM								9 9
	No valve								0 0
Type code		G	S	-					

**Standard

7.19 Wetted Parts RedySmart Series SN > 110 000

Instrument	Smart series SN > 110 000	
Version	Aluminium	Stainless steel <i>Edelstahl</i>
Body	Aluminium ¹	1.4305
Body: O-Rings	FKM (Standard), EPDM, PTFE	
Flow divider	Aluminium ²	1.4305
Manual valve: Body, spindle, nozzle	Ms58	1.4305
Manual valve: Needle	1.4112	
Manual valve: O-Rings	FKM (Standard), EPDM	
Control valve	1.4305/1.4105/1.6908	
Control valve: O-Rings	FKM (Standard), EPDM	
Sensor material	Silicon, silicon oxide, silicon nitride Epoxy	
Sensor packaging	Aluminium ²	1.4305

Abbreviation <i>Kurzbezeichnung</i>	Designation <i>Bezeichnung</i>	Remarks <i>Bemerkungen</i>
Aluminium1	Anticorodal 100/ Stanal 32	Anodized Eloxiert
Aluminium2	Anticorodal 100	Untreated Unbehandelt
EPDM	–	Ethylene-propylene-diene-monomer rubber Ethylen-Propylen-Dien-Kautschuk
Epoxy	–	Adhesive for sensor fixation, protection for wire bonding Klebstoff für Sensorfixierung, Schutz für Bonddrähte
FKM	–	Fluor rubber Fluor-Kautschuk
PBT	Pocan	Polybutylene terephthalate Polybutylenterephthalat
PTFE	Chemraz	Polytetrafluoroethylene Polytetrafluorethylen
Sainless Steel Edelstahl	-	1.4305

7.20 Change History

Date	Version	Replaces	Author	Note
06.07.2020	Smart_E6_7	Smart_E6_6	HAE	Display and sleep mode
22.06.2015	Smart_E6_6	Smart_E6_5	HAE	Accessories Graph update
08.10.2012	Smart_E6_5	Smart_E6_4	MRZ	Display
07.05.2012	smart_E6_4	smart_E6_3	MRZ	Technical data
06.02.2012	smart_E6_3	smart_E6_2	MRZ	LED Operating Status Display
09.03.2011	smart_E6_2	Smart_E6_1	HIE	Final Corrigenda
01.11.2010	smart_E6_1	-	MHU	Translation

8. Appendix B- Detailed Warranty Statement for RedySmart & RedyCompact Brands

In addition to Sierra's standard three (3) year manufacturing warranty on all MEMS mass flow instruments produced, Sierra also offers a Lifetime No-Drift Sensor Warranty. Sierra defines no-drift as less than 1% of full scale over the life of the instrument. Therefore, if drift of greater than 1% of full scale occurs over the sensor's lifetime, the sensor and/or entire instrument will be repaired or replaced and recalibrated free of charge.

This warranty applies to all MEMS/CMOS thermal mass flow sensors standard on every Sierra RedySmart™ and RedyCompact™ models sold after January 15, 2020. This warranty is only valid if the unit is exclusively used with the gas or gases specified during the initial calibration or recalibration, without any additives in any form and under the operating conditions (temperature, inlet and outlet pressure, full scale flow rate) the unit was originally specified for.

Sierra's Lifetime No-Drift Sensor Warranty is made possible due to high-precision MEMS (Micro-Electro Mechanical Systems) technology utilizing an advanced ultra-stable CMOS (Complementary Metal Oxide Semiconductor) sensor. The use of MEMS techniques allows both electronic circuits and mechanical devices to be manufactured on a silicon chip, similar to the process used for integrated circuits.

To assure warranty service, customers must register their products online on Sierra's website. Online registration of all of your Sierra products is required for our warranty process.

Warranty Limitations:

Warranty does not cover any damage or discoloration caused by particulates deposited by dirty gases, liquids, residue or any other source. Warranty does not cover usage of any corrosive gas not compatible with the wetted materials listed:

Wetted Material

Sensor Compartment

- Aluminum
- Stainless Steel

Sensor Element CMOS

- Silicon (Si)
- Silicon oxide (SiO_x)
- Silicon nitride (Si₃N₄)
- Stainless steel
- Hysol FP4450/4451TD
- Gold connectors

Sensor Compartment O-ring Sealing

- FKM

- EPDM / FFKM on request

Warranty does not cover electronics drift or recalibration expenses for any reason other than the failure described above. Such returns are contingent on Sierra's examination and reasonable satisfaction that any defects are covered by this warranty and that the customer has not returned the equipment in a damaged condition, due to any negligence, tampering, misapplication or product modification on the part of the customer or customer agents. Third party reports will not be accepted for warranty claims.

Sierra shall not be liable for installation charges, for expenses of customer for repairs or replacement, for damages from delay or loss of use, or other indirect or consequential damages of any kind. Sierra extends this warranty only to Sierra products properly used and properly installed for the particular application for which intended and quoted, and this warranty does not cover products which have been modified without Sierra's approval or which have been subjected to unusual physical or electrical stress, alteration, or tampering, or upon which the original identification marks have been removed or altered. Whenever the design of the equipment to be furnished or the system in which it is to be incorporated originates with the customer, Sierra's Lifetime No-Drift Sensor Warranty is limited specifically to matters relating to furnishing Sierra equipment free of defects in materials and workmanship and Sierra assumes no responsibility for implied warranties of fitness for purpose or use. Any replacement or repair shall be done by Sierra's factory by qualified technicians.

Index

A		I	
Accessories	49	Installation	11
Accessories general	49	Installation and commissioning	19
Appendix.....	36, 57	Installation get red-y	28
B		L	
Block diagram	13	LED Operating Status Display	23
Block diagram pressure control.....	32	M	
C		Maintenance / Calibration check	26
Calibration	17	measurement principle	12
Change history.....	55	Measurement ranges (air)	15
Characteristics pressure control.....	30	Mechanical specifications	14
Cleaning to remove contamination	26	Mounting position and location.....	19
CMOS technology	13	O	
Communication cable PDM-U	49	Other gases	17
Configuration get red-y	34	P	
Connection diagram pressure control	33	Pipework.....	19
Control behavior.....	18	Plug pin assignment, PROFIBUS	17
D		Power	11
Device specifications general	14	Pressure compensation	18
Digital communication.....	29	Pressure control.....	30
Dimensional drawings	44	Pressure conversion table.....	35
Display	24	Pressure loss	17, 42
Documentation supplied	12	R	
E		Requirements pressure control	30
Electrical connection	22	Response time	18
Electrical data	15	Return	27
Electrical power supply.....	21	S	
F		Scope of warranty	10
Features of thermal mass flow meters and controllers.....	10	Sealants.....	20
filter fittings	20	Serial interface	16
Filters / Gas cleanliness	20	Settings for control parameters.....	33
Flashing Alarm	23	T	
Flow splitter disassembly	27	Technical data	14
Functions get red-y.....	28	Technical data pressure control.....	32
G		Temperature compensation	18
get red-y software	28	Troubleshooting.....	11
Grounding.....	22	Troubleshooting flow rate	36

Troubleshooting pressure control 40
Type code GSM / GSC 50
Type code pressure controller 52

W

Warm-up time 26
Wetted parts 54